



# CEASE FIRE

The Fire and Safety Experts



**Over 500**  
Quality Products



**State-of-the-Art**  
Manufacturing



**International**  
Certifications



FIRE EXTINGUISHERS | IN-PANEL SYSTEMS | KITCHEN SYSTEMS | SUPPRESSION SYSTEMS | ACCESSORIES

# ABOUT US

Ceasefire UK is a 100% subsidiary of Ceasefire Industries, the most trusted fire safety brand in India and a fast emerging global conglomerate. With its globally certified, holistically integrated range of fire fighting solutions, the company is amongst the rarest in the world to have such a diverse product portfolio as part of one eco-system. The company is a leading manufacturer of a 360 degree unified product range that includes a complete line of Fire Extinguishers with -

the widest variety of extinguishing agents, **Special Application Extinguishers**, Highly advanced **In-Panel Suppression Systems, Total Flooding Systems**, Greenest technologies including **Inert Gas Based Suppression**, Revolutionary **Watermist Based Suppression Systems**, Extensive range of Watermist and Wet chemical Based **Kitchen Fire Suppression Systems, Hydrant System**, and other highly specialised fire fighting technologies.



This extensive product portfolio is built at the very forefront of technology and conforms to the highest global standards and carry a host of international certifications by world's top-notch quality agencies including - **BS EN3, BS EN1866, LPCB, BSI, EU-MED, PED, VdS, UKCA-MER, UKCA-PED, ISO 9001**. Manufactured at the company's state-of the art

production facility in India, Ceasefire's fire fighting solutions are setting global benchmarks in quality. Best names across industry segments globally have counted on us for their safety, including global giants, MNCs, Government Agencies, Railways, Airports and Military & Strategic Establishments. Totalling 500,000 customers, we've never let anyone down, ever.

## OUR CERTIFICATIONS



KM666994



LPCB Cert Ref. 1329b



2631



0832 / 2022



1128



## FIRE EXTINGUISHERS

### Core Range

Home And Car Extinguishers .....	08
ABC Powder Portable & Wheeled Extinguishers .....	11
CO <sub>2</sub> Portable & Wheeled Extinguishers .....	14
Water Portable & Wheeled Extinguishers .....	16
Foam Portable & Wheeled Extinguishers .....	18
Water Portable Extinguishers (Spray Model) .....	20
Foam Portable Extinguishers (Spray Model) .....	21

### Special Application

Watermist Portable Extinguishers .....	23
Foammist & Green-Foammist Portable Extinguishers .....	24
Action-Pac (Portable Watermist & Foammist) .....	26
CAFS (Watermist Compressed Air Foam System - Low Pressure) .....	27
QUAD (Watermist, Foammist & Green-Foammist Wheeled Extinguishers) .....	28
Tetraquad .....	29
Wet Chemical Portable Extinguishers .....	30
Fluoroketone Portable Extinguishers .....	32
B Plus Special Application (Class B) Extinguishers .....	33
Metal Fire Extinguishers .....	34

### Automatics

Automatic Fire Extinguishers (Wall Mounted) .....	36
Automatic Fire Extinguishers (Ceiling Mounted) .....	38
Ceasefire Mini .....	40
Launcher (Extinguisher + Modular Suppression System) .....	46

### Accessories

Ceasefire Instalert .....	48
Strolleys .....	48
Flat Pack Tubular Stand- Chrome & Red .....	49
Signages .....	51
Flat Pack Trolleys .....	54
Modular Plastic Stands .....	56
Flat Pack Fire Extinguisher Stand .....	56
Specially Designed Mounting Bracket .....	57

## SUPPRESSION SYSTEMS

In-Panel Tube Based Suppression System (CQRS) .....	62
Inert Gas Suppression System .....	64
Atom X .....	66
Automatic Fire Extinguishers (Wall Mounted) .....	69
Automatic Fire Extinguishers (Ceiling Mounted) .....	71
Ceasefire Mini .....	73
Launcher (Extinguisher + Modular Suppression System) .....	79
CF 3000 - Hydrant System .....	81

## KITCHEN SYSTEMS

Commercial Kitchen Suppression System - Enviro (Watermist based) .....	87
Commercial Kitchen Suppression System - Ultra (Wet Chemical based) .....	88
Residential Kitchen Suppression System - Enviro (Watermist based) .....	89
Residential Kitchen Suppression System - Ultra (Wet Chemical based) .....	90

## WATERMIST SUPPRESSION SYSTEMS

Nozzles .....	96
Generator Auto - Quell System .....	97
Transformer Auto - Quell System .....	98
Swift .....	99
Indoor Auto-Quell System .....	100

# FIRE EXTINGUISHERS

## IN THIS SECTION



Core Range



Special Application



Automatics



Accessories





# A FIRE EXTINGUISHERS RANGE WITH INCREDIBLE LENGTH & DEPTH

Ceasefire's range of extinguishers offer an unmatched length and depth. From Core Range Extinguishers including ABC Powder, Water, Foam & CO<sub>2</sub> to Specialized Extinguishers including Clean Agent, Metal Fire, Watermist, Foammist, Compressed Air Foam, Wet Chemical and Extinguishers for domestic use, the range is the most comprehensive ever.

The length of Ceasefire's range of extinguishers is complemented with an incredible depth too. The extinguishers are not only available in a wide variety of agents for unique application, but come in every size possible, ranging from small sizes of 500gms, 1kg & 2kg, 4kg, 5kg, 6kg, 9kg and 12kg to Plus sizes of 25kg, 50kg, 100kg and 250 Litres.



## Widest Range of Extinguishers To Address Every Kind of Fire.

Ceasefire has a complete line of fire extinguishers and extinguishing agents to address the needs of any type of facility or application.



CO<sub>2</sub> Extinguishers



Fluoroketone (FK) Extinguishers



Watermist Extinguishers

# THE MANUFACTURING EDGE

Our manufacturing facility is an ISO 9001 certified, state-of-the-art, backward-integrated production unit, with in-house container manufacturing, advance deep draw stations, In-house valve manufacturing, world-class paint shop and a highly sophisticated quality test lab.

The facility is fully compliant to the Factory Production Control (FPC) requirements of the highest global standards including BS EN3, BS EN1866, LPCB, BSI, EU-MED, PED and OHSAS.



In-house design cell. Company owned manufacturing facility in Dehradun, India.



Testing labs equipped to carry out quality-standardized tests.



In-house valve manufacturing unit.



ISO certified production facility.



Advanced MIG CO<sub>2</sub> welding station.



Tie-ups with the world's leading OEMs.



World class paint shop that ensures superior product quality.



Quality certifications from world's best agencies.



# EXTINGUISHERS PAR EXCELLENCE

Each of our extinguisher goes through the following mandatory tests:

## ■ HPT Test:

Hydrostatic Pressure Tested (HPT) with a pressure of 30kg/cm<sup>2</sup>, which is three times the working pressure of an extinguisher.



## ■ Inverted Beaker 24-hour Leak Test:

Pressurised extinguishers are immersed in water for 24 hours with an inverted glass beaker placed on the neck. Any trace of air bubbles symbolizes leakage and the extinguisher is rejected.

## ■ The Helium Leak Detection Test:

The container is charged with 99% Nitrogen and a small amount of Helium is added. Helium being lighter than air leaks out even if there is slightest trace of leakage in any joint. If so, the extinguisher is rejected.



## OUR EXTINGUISHERS ARE NOT JUST MANUFACTURED, THEY ARE ENGINEERED TO PERFECTION TO BECOME THE LIFESAVERS THEY ARE.

## ■ Deep Draw Body:

Portable extinguishers are manufactured using a state-of-the-art Deep Draw process ensuring minimal seams on the container body.



## ■ MIG CO<sub>2</sub> Welding:

Extinguishers are manufactured using advanced Motorized Metal Inert Gas Welding Technology giving them a much superior and stronger container body.

## ■ Internal Epoxy Coating:

Water/Foam/Wet chemicals extinguishers are treated with internal epoxy coating that ensures no rust or corrosion.



## ■ Treated for Longevity:

Ceasefire extinguishers are chemically treated internally and externally to ensure durability & longevity.

# Core Range of Fire Extinguishers

Built for Speed, Power, and  
Reliability.





# HOME AND CAR FIRE EXTINGUISHERS (CLASSIC RANGE)

## OVERVIEW:

Ceasefire's range of Home & Car extinguishers take the guesswork and confusion out of choosing an extinguisher and save valuable time. Mono Ammonium Phosphate being a potent firefighting agent maximises the fire fighting power. These extinguishers are easier to use than others because of their lightweight 'point and shoot' design.

## FEATURES:

- Most potent against Home & Car fires.
- Simplicity in design.
- Portable and easy to use.
- Colors to suit your home decor.
- State-of-the-art pressure gauge.
- Easy snap safety seal.
- World-class quality.



<b>FIGHTS CLASS</b>	<b>CERTIFICATIONS</b>
A B C ⚡	

Scan the QR code to know more about the product

## TECHNICAL SPECIFICATIONS: HOME & CAR CLASSIC RANGE

Nomenclature	Fire Ext 500gms MS SP Red Texture	Fire Ext 500gms MS SP Ivory Texture	Fire Ext 500gms MS SP Blue Texture	Fire Ext 500gms MS SP Silver Texture
Stored Pressure/Cartridge	Stored Pressure	Stored Pressure	Stored Pressure	Stored Pressure
Agent	ABC Powder Map 90	ABC Powder Map 90	ABC Powder Map 90	ABC Powder Map 90
Throw (min.)	3 meters	3 meters	3 meters	3 meters
Product Code	CF-000224	CF-000223	CF-000222	CF-000225
Certification type	PED	PED	PED	PED
PED	Yes	Yes	Yes	Yes
UKCA-PED	Yes	Yes	Yes	Yes
Gross Weight (approx.)	1.45 kg	1.45 kg	1.45 kg	1.45 kg
Net Mass (approx.)	0.500 kg	0.500 kg	0.500 kg	0.500 kg
Height of Fire Ext.(approx)	265 mm	265 mm	265 mm	265 mm
Discharge Mechanism	Thumb Triggered	Thumb Triggered	Thumb Triggered	Thumb Triggered
Can Construction	Deep Drawn & MIG Welded	Deep Drawn & MIG Welded	Deep Drawn & MIG Welded	Deep Drawn & MIG Welded
Valve/Cap Construction	Forging & Machining	Forging & Machining	Forging & Machining	Forging & Machining
External Coating	Epoxy Polyester Powder	Epoxy Polyester Powder	Epoxy Polyester Powder	Epoxy Polyester Powder
Warranty in Years	5	5	5	5
Min. Discharge Time	4 sec	4 sec	4 sec	4 sec
Working Pressure	15 Bar	15 Bar	15 Bar	15 Bar
Dia. of Shell (OD)	74.5 mm	74.5 mm	74.5 mm	74.5 mm
Operating Temperature	-30°C to +60°C	-30°C to +60°C	-30°C to +60°C	-30°C to +60°C
Hydrostatic Test Pressure	35 Bar	35 Bar	35 Bar	35 Bar
Body Thickness	1.2 mm	1.2 mm	1.2 mm	1.2 mm



TECHNICAL SPECIFICATIONS: HOME & CAR CLASSIC RANGE

Nomenclature	Fire Ext 1kg MS SP Red	Fire Ext 1 kg Red Texture	Fire Ext 1 kg Ivory Texture	Fire Ext 1 kg Blue Texture	Fire Ext 1 kg Silver Texture	Fire Ext 1 kg MS SP Red	Fire Ext 1 kg MS SP Red
Stored Pressure/Cartridge	Stored Pressure	Stored Pressure	Stored Pressure	Stored Pressure	Stored Pressure	Stored Pressure	Stored Pressure
Agent	ABC Powder Map 90	ABC Powder Map 90	ABC Powder Map 90	ABC Powder Map 90	ABC Powder Map 90	ABC Powder Map 50	ABC Powder Map 50
Throw (min.)	3 meters	3 meters	3 meters	3 meters	3 meters	3 meters	3 meters
Product Code	CF-000721**	CF-001185	CF-001105	CF-001106	CF-001107	CF-000803	CF-000730**
Certification type	BS EN3, PED, UKCA-PED, EU-MED, UKCA-MER	BS EN3, PED, UKCA-PED	BS EN3, PED, UKCA-PED	BS EN3, PED, UKCA-PED	BS EN3, PED, UKCA-PED	BS EN3, PED, UKCA-PED, EU-MED, UKCA-MER	BS EN3, PED, UKCA-PED, EU-MED, UKCA-MER
LPCB	Yes	Yes*	Yes*	Yes*	Yes*	Yes	Yes
Kitemark	Yes	No	No	No	No	Yes	Yes
PED	Yes	Yes	Yes	Yes	Yes	Yes	Yes
UKCA-PED	Yes	Yes	Yes	Yes	Yes	Yes	Yes
EU-MED	Yes	No	No	No	No	Yes	Yes
UKCA-MER	Yes	No	No	No	No	Yes	Yes
Gross Weight (approx.)	1.98 kg	1.98 kg	1.98 kg	1.98 kg	1.98 kg	1.98 kg	1.98 kg
Net Mass (approx.)	1 kg	1 kg	1 kg	1 kg	1 kg	1 kg	1 kg
Height of Fire Ext.(approx)	325 mm	325 mm	325 mm	325 mm	325 mm	350 mm	325 mm
Discharge Mechanism	Thumb Triggered	Thumb Triggered	Thumb Triggered	Thumb Triggered	Thumb Triggered	Squeeze Grip	Thumb Triggered
Fire Ratings	5A   21B	5A   21B	5A   21B	5A   21B	5A   21B	5A   34B	5A   34B
Can Construction	Deep Drawn & MIG Welded	Deep Drawn & MIG Welded	Deep Drawn & MIG Welded	Deep Drawn & MIG Welded	Deep Drawn & MIG Welded	Deep Drawn & MIG Welded	Deep Drawn & MIG Welded
Valve/Cap Construction	Forging & Machining	Forging & Machining	Forging & Machining	Forging & Machining	Forging & Machining	Forging & Machining	Forging & Machining
External Coating	Epoxy Polyester Powder Coated	Epoxy Polyester Powder Coated	Epoxy Polyester Powder Coated	Epoxy Polyester Powder Coated	Epoxy Polyester Powder Coated	Epoxy Polyester Powder Coated	Epoxy Polyester Powder Coated
Warranty in Years	5	5	5	5	5	5	5
Min. Discharge Time	9 sec	9 sec	9 sec	9 sec	9 sec	7 sec	8 sec
Working Pressure	15 Bar	15 Bar	15 Bar	15 Bar	15 Bar	15 Bar	15 Bar
Dia. of Shell (OD)	86.5 mm	86.5 mm	86.5 mm	86.5 mm	86.5 mm	86.5 mm	86.5 mm
Operating Temperature	-30°C to +60°C	-30°C to +60°C	-30°C to +60°C	-30°C to +60°C	-30°C to +60°C	-30°C to +60°C	-30°C to +60°C
Hydrostatic Test Pressure	35 Bar	35 Bar	35 Bar	35 Bar	35 Bar	35 Bar	35 Bar
Body Thickness	1 mm	1 mm	1 mm	1 mm	1 mm	1 mm	1 mm

\*Technical approval to EN 3 except EN 3-7 clause 16.1 LPCB ref 1329g.

\*\* Available with additional hanging bracket.



## HOME AND CAR FIRE EXTINGUISHERS (ART RANGE)

### OVERVIEW:

Designed to match the aesthetics of your home, so that it is easily accessible in an emergency. Ceasefire's Designer range of extinguishers are art installations of fine steel and ink, crafted to meet international standards and designed to exceed them. Making these extinguishers true works of art. Art that saves property and lives.

### FEATURES:

- Most potent against Home & Car fires.
- Simplicity in design.
- Portable and easy to use.
- Aesthetically pleasing designs to suit your home decor.
- State-of-the-art pressure gauge.
- Easy snap safety seal.
- World-class quality.



FIGHTS CLASS

CERTIFICATIONS

A B C ⚡ CE UK  
1128 CA



Scan the QR code to know more about the product

### TECHNICAL SPECIFICATIONS: HOME & CAR ART RANGE

Nomenclature	Fire Ext 500 gms MS SP Union Jack	Fire Ext 500 gms MS SP Hexalight	Fire Ext 500 gms MS SP Kiterunner	Fire Ext 1 kg MS SP Waves	Fire Ext 1 kg MS SP Elasticity
Stored Pressure/Cartridge	Stored Pressure	Stored Pressure	Stored Pressure	Stored Pressure	Stored Pressure
Agent	Abc Powder Map 90	ABC Powder Map 90	ABC Powder Map 90	ABC Powder Map 90	ABC Powder Map 90
Throw (min.)	3 meters	3 meters	3 meters	3 meters	3 meters
Product Code	CF-001315	CF-000946	CF-000947	CF-000951	CF-000954
Certification type	PED	PED	PED	PED	PED
PED	Yes	Yes	Yes	Yes	Yes
UKCA-PED	Yes	Yes	Yes	Yes	Yes
Gross Weight (approx.)	1.45 kg	1.45 kg	1.45 kg	2.30 kg	2.30 kg
Net Mass (approx.)	0.500 kg	0.500 kg	0.500 kg	1 kg	1 kg
Height of Fire Ext.(approx)	265 mm	265 mm	265 mm	325 mm	325 mm
Discharge Mechanism	Thumb Triggered	Thumb Triggered	Thumb Triggered	Thumb Triggered	Thumb Triggered
Fire Ratings	-	-	-	5A   21B	5A   21B
Can Construction	Deep Drawn & MIG Welded	Deep Drawn & MIG Welded	Deep Drawn & MIG Welded	Deep Drawn & MIG Welded	Deep Drawn & MIG Welded
Valve/Cap Construction	Forging & Machining	Forging & Machining	Forging & Machining	Forging & Machining	Forging & Machining
External Coating	Epoxy Polyester Powder Coated & Laminated	Epoxy Polyester Powder Coated & Laminated	Epoxy Polyester Powder Coated & Laminated	Epoxy Polyester Powder Coated & Laminated	Epoxy Polyester Powder Coated & Laminated
Warranty in Years	5	5	5	5	5
Min. Discharge Time	4 sec	4 sec	4 sec	9 sec	9 sec
Working Pressure	15 Bar	15 Bar	15 Bar	15 Bar	15 Bar
Dia. of Shell (OD)	74.5 mm	74.5 mm	74.5 mm	86.5 mm	86.5 mm
Operating Temperature	-30°C to +60°C	-30°C to +60°C	-30°C to +60°C	-30°C to +60°C	-30°C to +60°C
Hydrostatic Test Pressure	35 Bar	35 Bar	35 Bar	35 Bar	35 Bar
Body Thickness	1.2 mm	1.2 mm	1.2 mm	1.6 mm	1.6 mm





## ABC POWDER PORTABLE & WHEELED EXTINGUISHERS

### OVERVIEW:

In environments such as schools, offices, hospitals & factories, the Ceasefire ABC Powder extinguisher is your safest bet. Mono Ammonium Phosphate paired with a simple, controllable discharge mechanism maximises the firefighting power and puts out the fire within seconds.

### FEATURES:

- Fights Class A, B, C and Electrically started fires.
- Packed with 50% and 90% MAP concentration.
- State-of-the-art Pressure Gauge.
- Quick, powerful and reliable firefighting system.
- Equipped with Schraeder Valve and Pressure Relief Valve [available only in portable range].



ABC Powder Portable



Scan the QR code to know more about the product

### TECHNICAL SPECIFICATIONS: ABC POWDER MAP 90 PORTABLE EXTINGUISHERS

Nomenclature	Fire Ext 2Kg MS SP Red	Fire Ext 4Kg MS SP Red	Fire Ext 6Kg MS SP Red	Fire Ext 9Kg MS SP Red	Fire Ext 12Kg MS SP Red
Stored Pressure/Cartridge	Stored Pressure	Stored Pressure	Stored Pressure	Stored Pressure	Stored Pressure
Agent	ABC Powder Map 90	ABC Powder Map 90	ABC Powder Map 90	ABC Powder Map 90	ABC Powder Map 90
Throw (min.)	3.5 meters	4 meters	6 meters	7 meters	7 meters
Product Code	CF-000722**	CF-000723**	CF-000724	CF-000725**	CF-000726**
Certification type	BS EN3, PED, UKCA-PED, EU-MED, UKCA-MER	BS EN3, PED, UKCA-PED, EU-MED, UKCA-MER	BS EN3, PED, UKCA-PED, EU-MED, UKCA-MER	BS EN3, PED, UKCA-PED, EU-MED, UKCA-MER	BS EN3, PED, UKCA-PED
LPCB	Yes	Yes	Yes	Yes	Yes
Kitemark	Yes	Yes	Yes	Yes	No
PED	Yes	Yes	Yes	Yes	Yes
UKCA-PED	Yes	Yes	Yes	Yes	Yes
EU-MED	Yes	No	Yes	Yes	No
UKCA-MER	Yes	No	Yes	Yes	No
Gross Weight (approx.)	3.4 kg	6.5 kg	9.3 kg	13.4 kg	17.7 kg
Net Mass (approx.)	2 kg	4 kg	6 kg	9 kg	12 kg
Height of Fire Ext.(approx)	345 mm	440 mm	485 mm	615 mm	665 mm
Discharge Mechanism	Thumb Triggered	Squeeze Grip	Squeeze Grip	Squeeze Grip	Squeeze Grip
Fire Ratings	13A   55B	21A   144B	27A   183B	43A   233B	55A   233B
Can Construction	Deep Drawn & MIG Welded	Deep Drawn & MIG Welded	Deep Drawn & MIG Welded	Deep Drawn & MIG Welded	Deep Drawn & MIG Welded
Valve/Cap Construction	Forging & Machining	Forging & Machining	Forging & Machining	Forging & Machining	Forging & Machining
External Coating	Epoxy Polyester Powder	Epoxy Polyester Powder	Epoxy Polyester Powder	Epoxy Polyester Powder	Epoxy Polyester Powder
Warranty in Years	5	5	5	5	5
Min. Discharge Time	10 sec	15 sec	17 sec	17 sec	27 sec
Working Pressure	15 Bar	15 Bar	15 Bar	15 Bar	15 Bar
Dia. of Shell (OD)	108 mm	140 mm	160 mm	175 mm	204 mm
Operating Temperature	-30°C to +60°C	-30°C to +60°C	-30°C to +60°C	-30°C to +60°C	-30°C to +60°C
Hydrostatic Test Pressure	35 Bar	35 Bar	35 Bar	35 Bar	35 Bar
Body Thickness	1.4 mm	1.2 mm	1.4 mm	1.4 mm	1.6 mm
Schraeder Valve	No	Yes	Yes	Yes	Yes
Pressure relief valve	No	Yes	Yes	Yes	Yes

\*\* Available with additional hanging bracket.

## TECHNICAL SPECIFICATIONS: ABC POWDER MAP 50 PORTABLE EXTINGUISHERS

Nomenclature	Fire Ext 2Kg MS SP Red	Fire Ext 2Kg MS SP Red (Gun Housing)	Fire Ext 4Kg MS SP Red	Fire Ext 6Kg MS SP Red	Fire Ext 6Kg SS SP Chrome	Fire Ext 9Kg MS SP Red	Fire Ext 9Kg SS SP Chrome	Fire Ext 12Kg MS SP Red
Stored Pressure/ Cartridge	Stored Pressure	Stored Pressure	Stored Pressure	Stored Pressure	Stored Pressure	Stored Pressure	Stored Pressure	Stored Pressure
Agent	ABC Powder MAP 50	ABC Powder MAP 50	ABC Powder MAP 50	ABC Powder MAP 50	ABC Powder MAP 50	ABC Powder MAP 50	ABC Powder MAP 50	ABC Powder MAP 50
Throw (min.)	3.5 meters	3.5 meters	4 meters	6 meters	6 meters	7 meters	7 meters	7 meters
Product Code	CF-000804	CF-000731**	CF-000732**	CF-000733	CF-000990**	CF-000734**	CF-000991**	CF-000735**
Certification type	BS EN3, PED, UKCA-PED, EU-MED, UKCA-MER	BS EN3, PED, UKCA-PED, EU-MED, UKCA-MER	BS EN3, PED, UKCA-PED, EU-MED, UKCA-MER	BS EN3, PED, UKCA-PED, EU-MED, UKCA-MER	BS EN3, PED, UKCA-PED	BS EN3, PED, UKCA-PED, EU-MED, UKCA-MER	BS EN3, PED, UKCA-PED	BS EN3, PED, UKCA-PED, EU-MED, UKCA-MER
LPCB	Yes	Yes	Yes	Yes	Yes*	Yes	Yes*	Yes
Kitemark	Yes	Yes	Yes	Yes	No	Yes	No	No
PED	Yes	Yes	Yes	Yes	Yes	Yes	Yes	Yes
UKCA-PED	Yes	Yes	Yes	Yes	Yes	Yes	Yes	Yes
EU-MED	Yes	Yes	Yes	Yes	No	Yes	No	Yes
UKCA-MER	Yes	Yes	Yes	Yes	No	Yes	No	Yes
Gross Weight (approx.)	3.4 kg	3.4 kg	6.5 kg	9.3 kg	9.5 kg	13.4 kg	13.3 kg	17.7 kg
Net Mass (approx.)	2 kg	2 kg	4 kg	6 kg	6 kg	9 kg	9 kg	12 kg
Height of Fire Ext. (approx)	370 mm	345 mm	440 mm	485 mm	485 mm	615 mm	615 mm	665 mm
Discharge Mechanism	Squeeze Grip	Thumb Triggered	Squeeze Grip	Squeeze Grip	Squeeze Grip	Squeeze Grip	Squeeze Grip	Squeeze Grip
Fire Ratings	8A   70B	8A   70B	21A   144B	27A   183B	27A   183B	43A   233B	43A   233B	55A   233B
Can Construction	Deep Drawn & MIG Welded	Deep Drawn & MIG Welded	Deep Drawn & MIG Welded	Deep Drawn & MIG Welded	Drawn Rolled & MIG Welded	Deep Drawn & MIG Welded	Drawn Rolled & MIG Welded	Deep Drawn & MIG Welded
Valve/Cap Construction	Forging & Machining	Forging & Machining	Forging & Machining	Forging & Machining	Forging & Machining	Forging & Machining	Forging & Machining	Forging & Machining
External Coating	Epoxy Polyester Powder	Epoxy Polyester Powder	Epoxy Polyester Powder	Epoxy Polyester Powder	Chrome Finish	Epoxy Polyester Powder	Epoxy Polyester Powder	Epoxy Polyester Powder
Warranty in Years	5	5	5	5	5	5	5	5
Min. Discharge Time	11 sec	11 sec	16 sec	21 sec	21 sec	18 sec	18 sec	25 sec
Working Pressure	15 Bar	15 Bar	15 Bar	15 Bar	15 Bar	15 Bar	15 Bar	15 Bar
Dia. of Shell (OD)	108 mm	108 mm	140 mm	160 mm	160 mm	175 mm	175 mm	204 mm
Operating Temperature	-30°C to +60°C	-30°C to +60°C	-30°C to +60°C	-30°C to +60°C	-30°C to +60°C	-30°C to +60°C	-30°C to +60°C	-30°C to +60°C
Hydrostatic Test Pressure	35 Bar	35 Bar	35 Bar	35 Bar	35 Bar	35 Bar	35 Bar	35 Bar
Body Thickness	1.4 mm	1.4 mm	1.2 mm	1.4 mm	1.5 mm	1.4 mm	1.5 mm	1.6 mm
Schraeder Valve	Yes	No	Yes	Yes	Yes	Yes	Yes	Yes
Pressure relief valve	Yes	No	Yes	Yes	Yes	Yes	Yes	Yes

\* Technical approval to EN 3 except EN 3-7 clause 16.1 LPCB ref 1329g.

\*\* Available with additional hanging bracket.



## TECHNICAL SPECIFICATIONS: ABC POWDER MAP 50 WHEELED EXTINGUISHERS

Nomenclature	Fire Ext 25Kg MS SP Red	Fire Ext 50Kg MS SP Red	Fire Ext 100Kg MS SP Red
Stored Pressure/Cartridge	Stored Pressure	Stored Pressure	Stored Pressure
Agent	ABC Powder Map 50	ABC Powder Map 50	ABC Powder Map 50
Throw (min.)	6 meters	8 meters	10 meters
Product Code	CF-000808	CF-000809	CF-000810
Certification type	BS EN1866, PED, UKCA-PED, EU-MED, UKCA-MER	BS EN1866, PED, UKCA-PED, EU-MED, UKCA-MER	BS EN1866, PED, UKCA-PED, EU-MED, UKCA-MER
LPCB	Yes	Yes	Yes
Kitemark	Yes	Yes	Yes
PED	Yes	Yes	Yes
UKCA-PED	Yes	Yes	Yes
EU-MED	Yes	Yes	Yes
UKCA-MER	Yes	Yes	Yes
Gross Weight (approx.)	63 kg	112 kg	178.5 Kg
Net Mass (approx.)	25 kg	50 kg	100 kg
Height of Fire Ext.(approx)	990 mm	1200 mm	1495 mm
Discharge Mechanism	Operating Lever (Ball Valve)	Operating Lever (Ball Valve)	Operating Lever (Ball Valve)
Fire Ratings	A   IVB	A   IVB	A   IVB
Can Construction	Drawn Rolled & MIG Welded	Drawn Rolled & MIG Welded	Drawn Rolled & MIG Welded
Valve/Cap Construction	Forging & Machining	Forging & Machining	Forging & Machining
External Coating	Epoxy Polyester Powder Coating	Epoxy Polyester Powder Coating	Epoxy Polyester Powder Coating
Warranty in Years	5	5	5
Min. Discharge Time	15 sec	30 sec	60 sec
Working Pressure	15 Bar	15 Bar	15 Bar
Dia. of Shell (OD)	300 mm	400 mm	400 mm
Operating Temperature	-30°C to +60°C	-30°C to +60°C	-30°C to +60°C
Hydrostatic Test Pressure	30 Bar	30 Bar	30 Bar
Body Thickness	3 mm	3.5 mm	3.5 mm

## ABC Powder Wheeled



Scan the QR code to know more about the product



## CO<sub>2</sub> PORTABLE & WHEELED EXTINGUISHERS

### OVERVIEW:

Ceasefire's sturdy and light CO<sub>2</sub> extinguisher is very effective in putting out fires in larger spaces. Packed with tremendous power, it reduces the fire's oxygen supply, and brings the temperature down drastically, extinguishing the flames in seconds.

### FEATURES:

- Fights Class B, C and Electrically started fires.
- Advanced horn to dispense gas, removes risk of freeze burn.
- State-of-the-art Used/Ready indicator in selected range.

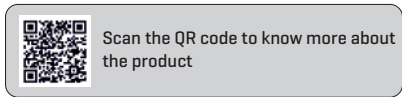

### TECHNICAL SPECIFICATIONS: CO<sub>2</sub> EXTINGUISHERS

Nomenclature	Fire Ext 2Kg MS SP Red	Fire Ext 2Kg Aluminium SP Red	Fire Ext 2Kg Aluminium SP Chrome	Fire Ext 5Kg MS SP Red	Fire Ext 5Kg Aluminium SP Red	Fire Ext 20Kg MS SP Red with Trolley
Stored Pressure/Cartridge	Stored Pressure	Stored Pressure	Stored Pressure	Stored Pressure	Stored Pressure	Stored Pressure
Agent	CO <sub>2</sub>	CO <sub>2</sub>	CO <sub>2</sub>	CO <sub>2</sub>	CO <sub>2</sub>	CO <sub>2</sub>
Throw (min.)	3 meters	3 meters	3 meters	4 meters	4 meters	5 meters
Product Code	TI-002393	TI-002391	TI-002455	TI-002394	TI-002392	CF-000740
Certification type	PED	PED	PED	PED	PED	BS EN1866, PED, UKCA-PED
LPCB	No	No	No	No	No	Yes
Kitemark	No	No	No	No	No	Yes
PED	Yes	Yes	Yes	Yes	Yes	Yes
UKCA-PED	No	No	No	No	No	Yes
EU-MED	No	No	No	No	No	No
UKCA-MER	No	No	No	No	No	No
Gross Weight (approx.)	8.8 kg	6.5 kg	6.5 kg	16.7 kg	12.122 kg	81.00 kg
Net Mass (approx.)	2 kg	2 kg	2 kg	5 kg	5 kg	20 Kg
Height of Fire Ext.(approx)	610 mm	605 mm	605 mm	825 mm	825 mm	1360 mm
Discharge Mechanism	Squeeze Grip	Squeeze Grip	Squeeze Grip	Squeeze Grip	Squeeze Grip	Wheel type
Fire Ratings	89B	55B	55B	34B	89B	113B
Can Construction	Hot Spinning Process	Cold Impact Extrusion	Cold Impact Extrusion	Hot Spinning Process	Cold Impact Extrusion	Hot Spinning
Valve/Cap Construction	Forging & Machining	Forging & Machining	Forging & Machining	Forging & Machining	Forging & Machining	Forging & Machining
External Coating	Epoxy Polyester Powder	Epoxy Polyester Powder	Chrome Finish	Epoxy Polyester Powder	Epoxy Polyester Powder	Epoxy Polyester Powder Coating
Warranty in Years	5	5	5	5	5	5
Min. Discharge Time	6 sec	6 sec	6 sec	9 sec	9 sec	18 sec
Working Pressure	62 Bar	62 Bar	62 Bar	70 Bar	67 Bar	70 Bar
Dia. of Shell (OD)	104 to 108 mm	111 mm	111 mm	136 to 140 mm	140 to 152 mm	232 mm
Operating Temperature	-30°C to +60°C	-30°C to +60°C	-30°C to +60°C	-30°C to +60°C	-30°C to +60°C	-30°C to +60°C
Hydrostatic Test Pressure	250 Bar	250 Bar	250 Bar	250 Bar	250 Bar	250 Bar
Body Thickness	2 to 3.5 mm	5.6 to 6 mm	5.6 to 6 mm	2.6 to 3 mm	5.6 to 8.7 mm	5.4 mm
Used & Ready Mechanism	No	No	No	No	No	Yes



# Water Extinguishers

Harness the Enormous Potential of Water



## WATER PORTABLE & WHEELED EXTINGUISHERS (JET MODEL)

### OVERVIEW:

Water has always been fire's deadliest foe. Ceasefire's Water extinguisher uses proprietary Stored Pressure Technology to deliver a high power throw of water. This ensures it fights fires effectively and enables the firefighter to maintain a safe distance from the flames.

### FEATURES:

- Fights Class A fires.
- EPDM / Braided Rubber Hosepipe.
- Easy Snap Safety Pin.
- State-of-the-art Pressure Gauge in portable range.
- Powder Coated cylinder liner.
- Deep Drawn Body in the portable range.
- Extinguishant dispersed via specially designed Jet Nozzle.
- Equipped with Schraeder Valve and Pressure Relief Valve [available only in portable range].



#### FIGHTS CLASS

A

#### CERTIFICATIONS



### Water Portable



Scan the QR code to know more about the product

### TECHNICAL SPECIFICATIONS: WATER PORTABLE EXTINGUISHERS

Nomenclature	Fire Ext 6L MS SP Red	Fire Ext 6L SS SP Chrome	Fire Ext 9L MS SP Red	Fire Ext 9L SS SP Chrome
Stored Pressure/Cartridge	Stored Pressure	Stored Pressure	Stored Pressure	Stored Pressure
Agent	Water	Water	Water	Water
Throw (min.)	7 meters	7 meters	7 meters	7 meters
Product Code	CF-000798**	CF-000988**	CF-000799**	CF-000989**
Certification type	BS EN3, PED, UKCA-PED, EU-MED, UKCA-MER	BS EN3, PED, UKCA-PED,	BS EN3, PED, UKCA-PED, EU-MED, UKCA-MER	BS EN3, PED, UKCA-PED,
LPCB	Yes	Yes*	Yes	Yes*
Kitemark	Yes	No	Yes	No
PED	Yes	Yes	Yes	Yes
UKCA-PED	Yes	Yes	Yes	Yes
EU-MED	Yes	No	Yes	No
UKCA-MER	Yes	No	Yes	No
Gross Weight (approx.)	9.3 kg	9.5 kg	13.3 kg	13.2 kg
Net Mass (approx.)	6 Ltr	6 Ltr	9 Ltr	9 Ltr
Height of Fire Ext.(approx)	520 mm	520 mm	615 mm	610 mm
Discharge Mechanism	Squeeze Grip	Squeeze Grip	Squeeze Grip	Squeeze Grip
Nozzle	Jet	Jet	Jet	Jet
Fire Ratings	13A	13A	21A	21A
Can Construction	Deep Drawn & MIG Welded	Drawn Rolled & MIG Welded	Deep Drawn & MIG Welded	Drawn Rolled & MIG Welded
Valve/Cap Construction	Forging & Machining	Forging & Machining	Forging & Machining	Forging & Machining
External Coating	Epoxy Polyester Powder	Chrome Finish	Epoxy Polyester Powder	Chrome Finish
Warranty in Years	5	5	5	5
Min. Discharge Time	9 sec	9 sec	9 sec	9 sec
Working Pressure	10 Bar	10 Bar	10 Bar	10 Bar
Dia. of Shell (OD)	160 mm	160 mm	175 mm	175 mm
Operating Temperature	+5°C to +60°C	+5°C to +60°C	+5°C to +60°C	+5°C to +60°C
Hydrostatic Test Pressure	35 Bar	35 Bar	35 Bar	35 Bar
Body Thickness	1.4 mm	1.5 mm	1.4 mm	1.5 mm
Schraeder Valve	Yes	Yes	Yes	Yes
Pressure relief valve	Yes	Yes	Yes	Yes

\*Technical approval to EN 3 except EN 3-7 clause 16.1 LPCB ref 1329g.

\*\* Available with additional hanging bracket.

## TECHNICAL SPECIFICATIONS: WATER WHEELED EXTINGUISHERS

Nomenclature	Fire Ext 50L MS SP Red	Fire Ext 50L SS SP Red	Fire Ext 100L MS SP Red	Fire Ext 100L SS SP Red
Stored Pressure/Cartridge	Stored Pressure	Stored Pressure	Stored Pressure	Stored Pressure
Agent	Water	Water	Water	Water
Throw (min.)	10 meters	10 meters	10 meters	10 meters
Product Code	CF-001031	CF-000755	CF-001033	CF-000886
Certification type	BS EN1866, PED, UKCA-PED, EU-MED, UKCA-MER	BS EN1866, PED, UKCA-PED	BS EN1866, PED, UKCA-PED, EU-MED, UKCA-MER	BS EN1866, PED, UKCA-PED
LPCB	Yes	Yes	Yes	Yes
Kitemark	Yes	Yes	Yes	Yes
PED	Yes	Yes	Yes	Yes
UKCA-PED	Yes	Yes	Yes	Yes
EU-MED	Yes	No	Yes	No
UKCA-MER	Yes	No	Yes	No
Gross Weight (approx.)	102.50 Kg	91.50 Kg	178.5 Kg	158.20 Kg
Net Mass (approx.)	50 Ltr	50 Ltr	100 Ltr	100 Ltr
Height of Fire Ext.(approx)	1510 mm	1510 mm	1520 mm	1520 mm
Discharge Mechanism	Operating Lever (Ball Valve)	Operating Lever (Ball Valve)	Operating Lever (Ball Valve)	Operating Lever (Ball Valve)
Nozzle	Jet	Jet	Jet	Jet
Fire Ratings	A	A	A	A
Can Construction	Drawn Rolled & MIG Welded	Drawn Rolled & MIG Welded	Drawn Rolled & MIG Welded	Drawn Rolled & MIG Welded
Valve/Cap Construction	Forging & Machining	Forging & Machining	Forging & Machining	Forging & Machining
Internal Coating	Epoxy Powder Coating	Epoxy Powder Coating	Epoxy Powder Coating	Epoxy Powder Coating
External Coating	Epoxy Polyester Powder Coating	Epoxy Polyester Powder Coating	Epoxy Polyester Powder Coating	Epoxy Polyester Powder Coating
Warranty in Years	5	5	5	5
Min. Discharge Time	40 sec	40 sec	80 sec	80 sec
Working Pressure	15 Bar	15 Bar	15 Bar	15 Bar
Dia. of Shell (OD)	300 mm	300 mm	400 mm	400 mm
Operating Temperature	+5°C to +60°C	+5°C to +60°C	+5°C to +60°C	+5°C to +60°C
Hydrostatic Test Pressure	30 Bar	30 Bar	30 Bar	30 Bar
Body Thickness	3 mm	1.8 mm	3.5 mm	2 mm

## Water Wheeled



Scan the QR code to know more about the product





## FOAM PORTABLE & WHEELED EXTINGUISHERS (ASPIRATING MODEL)

### OVERVIEW:

Fire needs oxygen to grow. Without it, even the largest fires die out in minutes. Ceasefire's Foam extinguisher exploits this weakness by discharging a mechanical foam that blankets the flames and cuts off the oxygen supply. It's what we like to call simple and effective firefighting.

### FEATURES:

- Fights Class A and B fires.
- State-of-the-art Pressure Gauge in portable range.
- Deep Drawn Body in the portable range.
- Stored Pressure technology for more effective firefighting.
- Squeeze Grip mechanism for quick and easy use.
- Equipped with Schraeder Valve and Pressure Relief Valve [available only in portable range].



Foam Portable



Scan the QR code to know more about the product

FIGHTS CLASS

CERTIFICATIONS

A B



### TECHNICAL SPECIFICATIONS: FOAM PORTABLE EXTINGUISHERS

Nomenclature	Fire Ext 3L MS SP Red	Fire Ext 3L SS SP Red	Fire Ext 6L SS SP Red	Fire Ext 6L SS SP Chrome	Fire Ext 9L MS SP Red	Fire Ext 9L SS SP Chrome
Stored Pressure/Cartridge	Stored Pressure	Stored Pressure	Stored Pressure	Stored Pressure	Stored Pressure	Stored Pressure
Agent	Water + 6% of KV Foam 3% C-6	Water + 6% of KV Foam 3% C-6	Water + 6% of KV Foam 3% C-6	Water + 6% of KV Foam 3% C-6	Water + 6% of KV Foam 3% C-6	Water + 6% of KV Foam 3% C-6
Throw (min.)	5 meters	5 meters	5 meters	5 meters	6 meters	6 meters
Product Code	CF-000805**	CF-000779**	CF-000806**	CF-000986**	CF-000807**	CF-000987**
Certification type	BS EN3, PED, UKCA-PED, EU-MED, UKCA-MER	BS EN3, PED, UKCA-PED, EU-MED, UKCA-MER	BS EN3, PED, UKCA-PED, EU-MED, UKCA-MER	BS EN3, PED, UKCA-PED	BS EN3, PED, UKCA-PED, EU-MED, UKCA-MER	BS EN3, PED, UKCA-PED
LPCB	Yes	Yes	Yes	Yes*	Yes	Yes*
Kitemark	Yes	Yes	Yes	No	Yes	No
PED	Yes	Yes	Yes	Yes	Yes	Yes
UKCA-PED	Yes	Yes	Yes	Yes	Yes	Yes
EU-MED	Yes	Yes	Yes	No	Yes	No
UKCA-MER	Yes	Yes	Yes	No	Yes	No
Gross Weight (approx.)	5.30 kg	6 kg	9.30 kg	9.5 kg	13.3 kg	13.3 kg
Net Mass (approx.)	3 Ltr	3 Ltr	6 Ltr	6 Ltr	9 Ltr	9 Ltr
Height of Fire Ext.(approx)	440 mm	435 mm	520 mm	515 mm	615 mm	610 mm
Discharge Mechanism	Squeeze Grip	Squeeze Grip	Squeeze Grip	Squeeze Grip	Squeeze Grip	Squeeze Grip
Nozzle	Aspirating	Aspirating	Aspirating	Aspirating	Aspirating	Aspirating
Fire Ratings	8A   89B	8A   89B	13A   144B	13A   144B	21A   233B	21A   233B
Can Construction	Deep Drawn & Mig Welded	Drawn Rolled & Mig Welded	Deep Drawn & Mig Welded	Drawn Rolled & Mig Welded	Deep Drawn & Mig Welded	Drawn Rolled & Mig Welded
Valve/Cap Construction	Forging & Machining	Forging & Machining	Forging & Machining	Forging & Machining	Forging & Machining	Forging & Machining
External Coating	Epoxy Polyester Powder	Epoxy Polyester Powder	Epoxy Polyester Powder	Chrome Finish	Epoxy Polyester Powder	Chrome Finish
Warranty in Years	5	5	5	5	5	5
Min. Discharge Time	9 sec	9 sec	15 sec	15 sec	15 sec	15 sec
Working Pressure	15 Bar	15 Bar	15 Bar	15 Bar	15 Bar	15 Bar
Dia. of Shell (OD)	140 mm	140 mm	160 mm	160 mm	175 mm	175 mm
Operating Temperature	+5°C to +60°C	+5°C to +60°C	+5°C to +60°C	+5°C to +60°C	+5°C to +60°C	+5°C to +60°C
Hydrostatic Test Pressure	35 Bar	35 Bar	35 Bar	35 Bar	35 Bar	35 Bar
Body Thickness	1.2 mm	1.5 mm	1.4 mm	1.5 mm	1.4 mm	1.5 mm
Schraeder Valve	Yes	Yes	Yes	Yes	Yes	Yes
Pressure relief valve	Yes	Yes	Yes	Yes	Yes	Yes

\*Technical approval to EN 3 except EN 3-7 clause 16.1 LPCB ref 1329g.

\*\* Available with additional hanging bracket.

## TECHNICAL SPECIFICATIONS: FOAM WHEELED EXTINGUISHERS

Nomenclature	Fire Ext 50L MS SP Red	Fire Ext 50L SS SP Red	Fire Ext 100L MS SP Red	Fire Ext 100L SS SP Red
Stored Pressure/Cartridge	Stored Pressure	Stored Pressure	Stored Pressure	Stored Pressure
Agent	Water + 6% of KV Foam 3% C-6	Water + 6% of KV Foam 3% C-6	Water + 6% of KV Foam 3% C-6	Water + 6% of KV Foam 3% C-6
Throw (min.)	7 meters	7 meters	7 meters	7 meters
Product Code	CF-001018	CF-000753	CF-001021	CF-001020
Certification type	BS EN1866, PED, UKCA-PED, EU-MED, UKCA-MER	BS EN1866, PED, UKCA-PED	BS EN1866, PED, UKCA-PED, EU-MED, UKCA-MER	BS EN1866, PED, UKCA-PED
LPCB	Yes	Yes	Yes	Yes
Kitemark	Yes	Yes	Yes	Yes
PED	Yes	Yes	Yes	Yes
UKCA-PED	Yes	Yes	Yes	Yes
EU-MED	Yes	No	Yes	No
UKCA-MER	Yes	No	Yes	No
Gross Weight (approx.)	101.5 Kg	90.50 Kg	177.50 Kg	158.50 Kg
Net Mass (approx.)	50 Ltr	50 Ltr	100 Ltr	100 Ltr
Height of Fire Ext.(approx)	1510 mm	1510 mm	1520 mm	1520 mm
Discharge Mechanism	Operating Lever (Ball Valve)	Operating Lever (Ball Valve)	Operating Lever (Ball Valve)	Operating Lever (Ball Valve)
Nozzle	Aspirating	Aspirating	Aspirating	Aspirating
Fire Ratings	A   IVB	A   IVB	A   IVB	A   IVB
Can Construction	Drawn Rolled & MIG Welded	Drawn Rolled & MIG Welded	Drawn Rolled & MIG Welded	Drawn Rolled & MIG Welded
Valve/Cap Construction	Forging & Machining	Forging & Machining	Forging & Machining	Forging & Machining
External Coating	Epoxy Polyester Powder Coating	Epoxy Polyester Powder Coating	Epoxy Polyester Powder Coating	Epoxy Polyester Powder Coating
Warranty in Years	5	5	5	5
Min. Discharge Time	40 sec	40 sec	80 sec	80 sec
Working Pressure	15 Bar	15 Bar	15 Bar	15 Bar
Dia. of Shell (OD)	300 mm	300 mm	400 mm	400 mm
Operating Temperature	+5°C to +60°C	+5°C to +60°C	+5°C to +60°C	+5°C to +60°C
Hydrostatic Test Pressure	30 Bar	30 Bar	30 Bar	30 Bar
Body Thickness	3 mm	1.8 mm	3.5 mm	2 mm

## Foam Wheeled



Scan the QR code to know more about the product



## WATER PORTABLE EXTINGUISHERS (SPRAY MODEL)

### OVERVIEW:

Water is a natural firefighting agent that helps bring down the temperature of the fire and the area around it. Ceasefire's Water Spray model extinguishers can be used on Class A, F, and Electrically started fires, making them more effective against the fire.

### FEATURES:

- Fights class A, F & Electrically Started Fires.
- EPDM/Braided Rubber Hosepipe.
- Easy Snap Safety Pin.
- State-of-the-art Pressure Gauge.
- Powder Coated cylinder liner.
- Deep Drawn cylinder construction.
- Extinguishant dispersed via specially designed Spray Nozzle.
- Suitable for use on live electrical equipment upto 1000 V from a distance of 1 meter.



Scan the QR code to know more about the product

### TECHNICAL SPECIFICATIONS: WATER SPRAY MODEL EXTINGUISHERS

Nomenclature	Fire Ext Water 6L MS SP Red	Fire Ext Water 6L SS SP Red	Fire Ext Water 9L MS SP Red	Fire Ext Water 9L SS SP Red
Stored Pressure/Cartridge	Stored Pressure	Stored Pressure	Stored Pressure	Stored Pressure
Agent	Water	Water	Water	Water
Throw (min.)	7 meters	7 meters	7 meters	7 meters
Product Code	CF-000798S	CF-000717S	CF-000799S	CF-000718S
Certification type	BS EN3, PED, UKCA-PED	BS EN3, PED, UKCA-PED	BS EN3, PED, UKCA-PED	BS EN3, PED, UKCA-PED
LPCB	Yes	Yes	Yes	Yes
Kitemark	Yes*	Yes*	Yes*	Yes*
PED	Yes	Yes	Yes	Yes
UKCA-PED	Yes	Yes	Yes	Yes
Gross Weight (approx.)	9.80 kg	9.80 kg	14.50 kg	14.50 kg
Net Mass (approx.)	6 Ltr	6 Ltr	9 Ltr	9 Ltr
Height of Fire Ext.(approx)	520 mm	520 mm	615 mm	610 mm
Discharge Mechanism	Squeeze Grip	Squeeze Grip	Squeeze Grip	Squeeze Grip
Nozzle	Spray	Spray	Spray	Spray
Fire Ratings	13A   25F	13A   25F	21A   40F	21A   40F
Can Construction	Deep Drawn & MIG Welded	Drawn Rolled & MIG Welded	Deep Drawn & MIG Welded	Drawn Rolled & MIG Welded
Valve/Cap Construction	Forging & Machining	Forging & Machining	Forging & Machining	Forging & Machining
External Coating	Epoxy Polyester Powder	Epoxy Polyester Powder	Epoxy Polyester Powder	Epoxy Polyester Powder
Warranty in Years	5	5	5	5
Min. Discharge Time	9 sec	9 sec	9 sec	9 sec
Working Pressure	10 Bar	10 Bar	10 Bar	10 Bar
Dia. of Shell (OD)	160 mm	160 mm	175 mm	175 mm
Operating Temperature	+5°C to +60°C	+5°C to +60°C	+5°C to +60°C	+5°C to +60°C
Hydrostatic Test Pressure	35 Bar	35 Bar	35 Bar	35 Bar
Body Thickness	1.6 mm	1.5 mm	2 mm	1.5 mm
Schraeder Valve	Yes	Yes	Yes	Yes
Pressure relief valve	Yes	Yes	Yes	Yes

\*Certification in process. Kindly check before ordering.

## FOAM PORTABLE EXTINGUISHERS (SPRAY MODEL)

### OVERVIEW:

The quickest way to kill a fire is by limiting the oxygen supply in the vicinity. Ceasefire's Foam Spray model extinguishers forms a foam blanket, cutting down on the oxygen supply. It works on Class A, B, F, and Electrically started fires.

### FEATURES:

- Fights class A, B, F & Electrically Started Fires.
- Deep Drawn cylinder construction.
- Stored Pressure technology for more effective firefighting.
- Squeeze Grip mechanism for quick and easy use.
- Equipped with Schraeder Valve and Pressure Relief Valve.
- Suitable for use on live electrical equipment upto 1000 V from a distance of 1 meter.

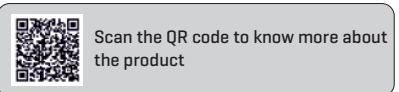

### TECHNICAL SPECIFICATIONS: FOAM SPRAY MODEL EXTINGUISHERS

Nomenclature	Fire Ext Foam 3L MS SP Red	Fire Ext Foam 3L SS SP Red	Fire Ext Foam 6L MS SP Red	Fire Ext Foam 6L SS SP Red	Fire Ext Foam 9L MS SP Red	Fire Ext Foam 9L SS SP Red
Stored Pressure/Cartridge	Stored Pressure	Stored Pressure	Stored Pressure	Stored Pressure	Stored Pressure	Stored Pressure
Agent	Water + 6% of KV Foam 3% C-6	Water + 6% of KV Foam 3% C-6	Water + 6% of KV Foam 3% C-6	Water + 6% of KV Foam 3% C-6	Water + 6% of KV Foam 3% C-6	Water + 6% of KV Foam 3% C-6
Throw (min.)	5 meters	5 meters	5 meters	5 meters	6 meters	6 meters
Product Code	CF-000805S	CF-000779S	CF-000806S	CF-000715S	CF-000807S	CF-000716S
Certification type	BS EN3, PED, UKCA-PED	BS EN3, PED, UKCA-PED	BS EN3, PED, UKCA-PED	BS EN3, PED, UKCA-PED	BS EN3, PED, UKCA-PED	BS EN3, PED, UKCA-PED
LPCB	Yes	Yes	Yes	Yes	Yes	Yes
Kitemark	Yes*	Yes*	Yes*	Yes*	Yes*	Yes*
PED	Yes	Yes	Yes	Yes	Yes	Yes
UKCA-PED	Yes	Yes	Yes	Yes	Yes	Yes
Gross Weight (approx.)	5.75 kg	5.7 kg	9.53 kg	9.53 kg	14.92 kg	13.5 kg
Net Mass (approx.)	3 Ltr	3 Ltr	6 Ltr	6 Ltr	9 Ltr	9 Ltr
Height of Fire Ext.(approx)	440 mm	435 mm	520 mm	520 mm	615 mm	610 mm
Discharge Mechanism	Squeeze Grip	Squeeze Grip	Squeeze Grip	Squeeze Grip	Squeeze Grip	Squeeze Grip
Nozzle	Spray	Spray	Spray	Spray	Spray	Spray
Fire Ratings	8A   89B   25F	8A   89B   25F	13A   144B   40F	13A   144B   40F	21A   233B   75F	21A   233B   75F
Can Construction	Deep Drawn & MIG Welded	Drawn Rolled & MIG Welded	Deep Drawn & MIG Welded	Drawn Rolled and MIG Welded	Deep Drawn & MIG Welded	Drawn Rolled & MIG Welded
Valve/Cap Construction	Forging & Machining	Forging & Machining	Forging & Machining	Forging & Machining	Forging & Machining	Forging & Machining
External Coating	Epoxy Polyester Powder	Epoxy Polyester Powder	Epoxy Polyester Powder	Epoxy Polyester Powder	Epoxy Polyester Powder	Epoxy Polyester Powder
Warranty in Years	5	5	5	5	5	5
Min. Discharge Time	9 sec	9 sec	15 sec	15 sec	15 sec	15 sec
Working Pressure	15 Bar	15 Bar	15 Bar	15 Bar	15 Bar	15 Bar
Dia. of Shell (OD)	140 mm	140 mm	160 mm	160 mm	175 mm	175 mm
Operating Temperature	+5°C to +60°C	+5°C to +60°C	+5°C to +60°C	+5°C to +60°C	+5°C to +60°C	+5°C to +60°C
Hydrostatic Test Pressure	35 Bar	35 Bar	35 Bar	35 Bar	35 Bar	35 Bar
Body Thickness	1.6 mm	1.5 mm	1.6 mm	1.5 mm	2 mm	1.5 mm
Schraeder Valve	Yes	Yes	Yes	Yes	Yes	Yes
Pressure relief valve	Yes	Yes	Yes	Yes	Yes	Yes

\*Certification in process. Kindly check before ordering.



# Special Application Extinguishers

To Protect High Risk  
Spaces.



## WATERMIST PORTABLE EXTINGUISHERS

### OVERVIEW:

The cleanest extinguishing agent known to man - Water. These extinguishers use stored pressure technology, advanced rotors and specially designed nozzles to generate an ultra fine spray of water called Watermist. Blocking the entry of oxygen in the fire zone and bringing down the temperature to below combustion levels. Enter the Ceasefire watermist fire fighting systems that increase the power of water 400 times over.

### FEATURES:

- Fights class A, F and Electrically started fires.
- Green extinguishing technology.
- Low water usage.
- Stainless steel containers.
- Environment friendly.
- Suitable for use on live electrical equipment upto 1000 V from a distance of 1 meter.

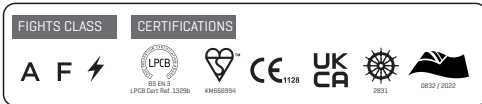

Scan the QR code to know more about the product

### TECHNICAL SPECIFICATIONS: WATERMIST PORTABLE EXTINGUISHERS

Nomenclature	Fire Ext Watermist 2L SS SP Red	Fire Ext Watermist 3L SS SP Red	Fire Ext Watermist 6L SS SP Red	Fire Ext Watermist 9L SS SP Red
Stored Pressure/Cartridge	Stored Pressure	Stored Pressure	Stored Pressure	Stored Pressure
Agent	Water	Water	Water	Water
Throw (min.)	3 meters	3 meters	3 meters	3 meters
Product Code	CF-000709*	CF-000710*	CF-000711*	CF-000712*
Certification type	BS EN3, PED, UKCA-PED	BS EN3, PED, UKCA-PED, EU-MED, UKCA-MER	BS EN3, PED, UKCA-PED, EU-MED, UKCA-MER	BS EN3, PED, UKCA-PED, EU-MED, UKCA-MER
LPCB	Yes	Yes	Yes	Yes
Kitemark	Yes	Yes	Yes	Yes
PED	Yes	Yes	Yes	Yes
UKCA-PED	Yes	Yes	Yes	Yes
EU-MED	No	Yes	Yes	Yes
UKCA-MER	No	Yes	Yes	Yes
Gross Weight (approx.)	4.5 kg	5.9 kg	10.6 kg	14.6 kg
Net Mass (approx.)	2 Ltr	3 Ltr	6 Ltr	9 Ltr
Height of Fire Ext.(approx)	485 mm	445 mm	575 mm	690 mm
Discharge Mechanism	Squeeze Grip	Squeeze Grip	Squeeze Grip	Squeeze Grip
Fire Ratings	5A   25F	8A   25F	13A   75F	21A   75F
Can Construction	Drawn Rolled & MIG Welded	Drawn Rolled & MIG Welded	Drawn Rolled & MIG Welded	Drawn Rolled & MIG Welded
Valve/Cap Construction	Forging & Machining	Forging & Machining	Forging & Machining	Forging & Machining
External Coating	Epoxy Polyester Powder	Epoxy Polyester Powder	Epoxy Polyester Powder	Epoxy Polyester Powder
Warranty in Years	5	5	5	5
Min. Discharge Time	6 sec	9 sec	9 sec	9 sec
Working Pressure	15 Bar	15 Bar	15 Bar	15 Bar
Dia. of Shell (OD)	108 mm	140 mm	175 mm	175 mm
Operating Temperature	+5°C to +60°C	+5°C to +60°C	+5°C to +60°C	+5°C to +60°C
Hydrostatic Test Pressure	35 Bar	35 Bar	35 Bar	35 Bar
Body Thickness	1.5 mm	1.5 mm	1.5 mm	1.5 mm
Schraeder Valve	Yes	Yes	Yes	Yes
Pressure relief valve	Yes	Yes	Yes	Yes

\* Available with additional hanging bracket.



## FOAM MIST & GREEN-FOAM MIST PORTABLE EXTINGUISHERS

### OVERVIEW:

Ceasefire Foam mist extinguisher range, harness the combined power of the revolutionary watermist technology and foam in its range of extinguishers. The foam mist fire fighting system forms a foam blanket on top of the fire, thereby eliminating entry of oxygen and killing the fire instantly.

### FEATURES:

- Fights class A, B, F and Electrically started fires.
- Green extinguishing technology.
- Low water usage.
- Highly safe and effective.
- Environment-friendly.
- Suitable for use on live electrical equipment upto 1000 V from a distance of 1 meter.

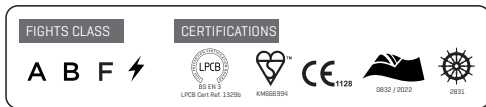

### TECHNICAL SPECIFICATIONS: FOAM MIST & GREEN-FOAM MIST PORTABLE EXTINGUISHERS

Nomenclature	Fire Ext Foam Mist 2L SS SP Red	Fire Ext Foam Mist 6L SS SP Red	Fire Ext Green Foam Mist 2L SS SP Red	Fire Ext Green Foam Mist 6L SS SP Red
Stored Pressure/Cartridge	Stored Pressure	Stored Pressure	Stored Pressure	Stored Pressure
Agent	Telesolve 1%	Telesolve 1%	0.5% of Telesolve 1%	0.5% of Telesolve 1%
Throw (min.)	3 meters	3 meters	3 meters	3 meters
Product Code	CF-000696*	CF-000698*	CF-000838*	CF-000839*
Certification type	BS EN3, PED, UKCA-PED, EU-MED, UKCA-MER	BS EN3, PED, UKCA-PED, EU-MED, UKCA-MER	BS EN3, PED, UKCA-PED	BS EN3, PED, UKCA-PED
LPCB	Yes	Yes	Yes	Yes
Kitemark	Yes	Yes	Yes	Yes
PED	Yes	Yes	Yes	Yes
UKCA-PED	Yes	Yes	Yes	Yes
EU-MED	Yes	Yes	No	No
UKCA-MER	Yes	Yes	No	No
Gross Weight (approx.)	4.5 kg	10.6 kg	4.5 kg	10.6 kg
Net Mass (approx.)	2 Ltr	6 Ltr	2 Ltr	6 Ltr
Height of Fire Ext.(approx)	485 mm	575 mm	415 mm	466 mm
Discharge Mechanism	Squeeze Grip	Squeeze Grip	Squeeze Grip	Squeeze Grip
Fire Ratings	5A   55B   25F	13A   144B   40F	5A   34B   25F	13A   133B   40F
Can Construction	Drawn Rolled & MIG Welded	Drawn Rolled & MIG Welded	Drawn Rolled & MIG Welded	Drawn Rolled & MIG Welded
Valve/Cap Construction	Forging & Machining	Forging & Machining	Forging & Machining	Forging & Machining
External Coating	Epoxy Polyester Powder	Epoxy Polyester Powder	Epoxy Polyester Powder	Epoxy Polyester Powder
Warranty in Years	5	5	5	5
Min. Discharge Time	9 sec	15 sec	6 sec	12 sec
Working Pressure	15 Bar	15 Bar	15 Bar	15 Bar
Dia. of Shell (OD)	108 mm	175 mm	109 mm	175 mm
Operating Temperature	+5°C to +60°C	+5°C to +60°C	+5°C to +60°C	+5°C to +60°C
Hydrostatic Test Pressure	35 Bar	35 Bar	35 Bar	35 Bar
Body Thickness	1.5 mm	1.5 mm	1.5 mm	1.5 mm
Schraeder Valve	Yes	Yes	Yes	Yes
Pressure relief valve	Yes	Yes	Yes	Yes

\* Available with additional hanging bracket.

Foammist



Scan the QR code to know more about the product

Green-Foammist



Scan the QR code to know more about the product



Widest Range of  
**Watermist  
Extinguisher**  
To Suit Every Kind of  
Premises.



## ACTION-PAC (PORTABLE WATERMIST AND FOAMMIST)

### OVERVIEW:

Presenting the Ceasefire Action-Pac extinguisher, the first of its kind in the world. Powered by 100% Green Watermist, this backpack & trolley mounted fire extinguisher is packed with immense fire fighting power and can easily be carried to the scene of the fire to battle the flames.

### FEATURES:

- Fights class A, B and Electrically started fires.
- 1 minute of continuous discharge, without flooding.
- Creates a fine mist of under 80 microns.
- Environment-friendly.
- Specially designed Discharge Gun employs either spray or jet mode.
- Thermal shock proof.
- Built in Trolley or Backpack.



FIGHTS CLASS

CERTIFICATIONS

A B ⚡ CE<sup>128</sup> UKCA



Scan the QR code to know more about the product

### TECHNICAL SPECIFICATIONS: ACTION-PAC EXTINGUISHERS

Nomenclature	Action-Pac Fire Extinguisher Watermist 13L SS SP Red	Action-Pac Fire Extinguisher Foam Mist 13L SS SP Red
Agent	Water	Water + 1% Telesolve Foam
Throw (min.)	Jet - 6 meters   Spray - 3 meters	Jet - 6 meters   Spray - 3 meters
Product Code	CF-000642	CF-000679
Certification type	PED, UKCA-PED	PED, UKCA-PED
PED	Yes	Yes
UKCA-PED	Yes	Yes
Gross Weight (approx.)	37.48 kg	37.48 kg
Net Mass (approx.)	13 Ltr	13 Ltr
Height of Fire Ext. (approx.)	745 mm	745 mm
Discharge Mechanism	Trigger Operated Gun	Trigger Operated Gun
Fire Ratings	27A*	43A   IVB
Can Construction	Drawn Rolled & MIG Welded	Drawn Rolled & MIG Welded
Valve / Cap Construction	Machining	Machining
External Coating	Epoxy Polyester Powder	Epoxy Polyester Powder
Warranty in Years	5	5
Min. Discharge Time	41 sec	15 sec
Working Pressure	15 Bar	15 Bar
Dia. of Shell (OD)	175 mm	175 mm
Operating Temperature	+5°C to +60°C	+5°C to +60°C
Hydrostatic Test Pressure	35 Bar	35 Bar
Body Thickness	1.5 mm	1.5 mm

\*Rating is self-verified.



## CAFS (WATERMIST COMPRESSED AIR FOAM SYSTEM - LOW PRESSURE)

### OVERVIEW:

Ceasefire's Compressed Air Foam System uses a specially designed discharge gun that expels approximately 100-micron sized droplets with a kinetic force strong enough to overcome the fire's convection currents. The watermist turns into steam, evaporates, and stops the fire from spreading. The foam component has a blanketing effect on the fire. The system is safe to use on Class B fires like petrol, diesel, and electrically started fires—two areas where traditional water applications would either spread the fire or cause an electrical shock.

### FEATURES:

- Fights class A, B and Electrically started fires.
- Dual phase extinguishing gun with an adjustable nozzle.
- Pure water-based green extinguishing technology.
- Thermal shock proof.
- No collateral damage.



Tested by **bsi.**

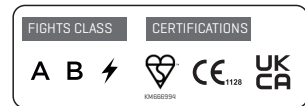

### TECHNICAL SPECIFICATIONS: CAFS

Nomenclature	CAFS Fire Extinguisher Foam Mist 9L SS CT Red Low Pressure	CAFS Fire Extinguisher Foam Mist 50L SS CT Red Low Pressure
Stored Pressure / Cartridge	Cartridge Type	Cartridge Type
Agent	AFFF Foam 6%	AFFF Foam 6%
Throw (min.)	12 meters	16 meters
Product Code	CF-000781	CF-000782
Certification type	PED, UKCA-PED, BSI Tested	BS EN1866, PED, UKCA-PED
Kitemark	No	Yes
PED	Yes	Yes
UKCA-PED	Yes	Yes
Gross Weight (approx.)	24.8 kg	102.5 kg
Net Mass (approx.)	9 Ltr	50 Ltr
Height of Fire Ext. (approx.)	575 mm	1200 mm
Discharge Mechanism	Trigger Operated Gun	Trigger Operated Gun
Fire Ratings	27A   233B	21A   IIB
Can Construction	Deep Drawn & MIG Welded	Drawn Rolled & MIG Welded
Valve / Cap Construction	Machining	Machining
External Coating	Epoxy Polyester Powder	Epoxy Polyester Powder Coating
Warranty in Years	5	5
Min. Discharge Time	40 to 42 sec	120 sec
Working Pressure	8 Bar	8 to 8.5 Bar
Dia. of Shell (OD)	204 mm	300 mm
Operating Temperature	+5°C to +60°C	+5°C to +60°C
Hydrostatic Test Pressure	35 Bar	30 Bar
Body Thickness	1.5 mm	2 mm



Scan the QR code to know more about the product

# QUAD [WATERMIST, FOAM MIST & GREEN-FOAM MIST WHEELED EXTINGUISHERS]

## OVERVIEW:

Ceasefire Quad brings together the efficiency of a fire extinguisher with the power of a hydrant system. It breaks water down into a fine mist of under 80 microns and covers a large surface area, reducing the temperature to below combustion levels. Meant for areas where fire risk is huge, or where large amounts of combustible materials are stored, the trolley-mounted Quad can be taken anywhere with ease.

## FEATURES:

- Fights class A, B, C, F and Electrically started fires.
- Green extinguishing technology.
- Low water usage.
- Highly safe and effective.
- Environment-friendly.
- Suitable for use on live electrical equipment upto 1000V from a distance of 1 meter.



**FIGHTS CLASS**

**A B** ⚡

**CERTIFICATIONS**

Scan the QR code to know more about the product

## TECHNICAL SPECIFICATIONS: QUAD [WATERMIST, FOAM MIST & GREEN-FOAM MIST WHEELED EXTINGUISHERS]

Nomenclature	Fire Ext Watermist 25L SS SP Red with Trolley	Fire Ext Watermist 50L SS SP Red with Trolley	Fire Ext Watermist 100L SS SP Red with Trolley	Fire Ext Foam Mist 25L SS SP Red Jet with Trolley	Fire Ext Foam Mist 50L SS SP Red Jet with Trolley	Fire Ext Foam Mist 100L SS SP Red Jet with Trolley	Fire Ext Green Foam Mist 25L SS SP Red with Trolley	Fire Ext Green Foam Mist 50L SS SP Red with Trolley	Fire Ext Green Foam Mist 100L SS SP Red with Trolley
Stored Pressure/ Cartridge	Stored Pressure	Stored Pressure	Stored Pressure	Stored Pressure	Stored Pressure	Stored Pressure	Stored Pressure	Stored Pressure	Stored Pressure
Agent	Water	Water	Water	Telesolve 1%	Telesolve 1%	Telesolve 1%	0.5% of Telesolve 1%	0.5% of Telesolve 1%	0.5% of Telesolve 1%
Throw	4 meters	4 meters	4 meters	10 meters	10 meters	10 meters	10 meters	10 meters	10 meters
Product Code	CF-000741	CF-000742	CF-000743	CF-000744	CF-000745	CF-000746	CF-000750	CF-000751	CF-000752
Certification type	BS EN1866, PED, UKCA-PED, EU-MED, UKCA-MER	BS EN1866, PED, UKCA-PED, EU-MED, UKCA-MER	BS EN1866, PED, UKCA-PED, EU-MED, UKCA-MER	BS EN1866, PED, UKCA-PED, EU-MED, UKCA-MER	BS EN1866, PED, UKCA-PED, EU-MED, UKCA-MER	BS EN1866, PED, UKCA-PED, EU-MED, UKCA-MER	BS EN1866, PED, UKCA-PED	BS EN1866, PED, UKCA-PED	BS EN1866, PED, UKCA-PED
LPCB	Yes	Yes	Yes	Yes	Yes	Yes	Yes	Yes	Yes
Kitemark	Yes	Yes	Yes	Yes	Yes	Yes	Yes	Yes	Yes
PED	Yes	Yes	Yes	Yes	Yes	Yes	Yes	Yes	Yes
UKCA-PED	Yes	Yes	Yes	Yes	Yes	Yes	Yes	Yes	Yes
EU-MED	Yes	Yes	Yes	Yes	Yes	Yes	No	No	No
UKCA-MER	Yes	Yes	Yes	Yes	Yes	Yes	No	No	No
Gross Weight (approx.)	65 kg	106.8 kg	166.2 kg	66.5 kg	107.5 kg	166.7 kg	66.5 kg	107.5 kg	166.7 kg
Net Mass (approx.)	25 ltr	50 Ltr	100 ltr	25 ltr	50 Ltr	100 Ltr	25 Ltr	50 ltr	100 ltr
Height of Fire Ext. (approx.)	1075 mm	1200 mm	1615 mm	1075 mm	1200 mm	1615 mm	1075 mm	1200 mm	1615 mm
Discharge Mechanism	Operating Lever (Ball Valve)	Operating Lever (Ball Valve)	Operating Lever (Ball Valve)	Operating Lever (Ball Valve)	Operating Lever (Ball Valve)	Operating Lever (Ball Valve)	Operating Lever (Ball Valve)	Operating Lever (Ball Valve)	Operating Lever (Ball Valve)
Fire Ratings	A	A	A	A   IVB	A   IVB	A   IVB	A   IB	A   IVB	A   IVB
Can Construction	Drawn Rolled & MIG Welded	Drawn Rolled & MIG Welded	Drawn Rolled & MIG Welded	Drawn Rolled & MIG Welded	Drawn Rolled & MIG Welded	Drawn Rolled & MIG Welded	Drawn Rolled & MIG Welded	Drawn Rolled & MIG Welded	Drawn Rolled & MIG Welded
Valve / Cap Construction	Forging & Machining	Forging & Machining	Forging & Machining	Forging & Machining	Forging & Machining	Forging & Machining	Forging & Machining	Forging & Machining	Forging & Machining
External Coating	Epoxy Polyester Powder Coating	Epoxy Polyester Powder Coating	Epoxy Polyester Powder Coating	Epoxy Polyester Powder Coating	Epoxy Polyester Powder Coating	Epoxy Polyester Powder Coating	Epoxy Polyester Powder Coating	Epoxy Polyester Powder Coating	Epoxy Polyester Powder Coating
Warranty in Years	5	5	5	5	5	5	5	5	5
Min. Discharge Time	20 sec	40 sec	80 sec	20 sec	40 sec	80 sec	20 sec	40 sec	80 sec
Working Pressure	15 Bar	15 Bar	15 Bar	15 Bar	15 Bar	15 Bar	15 Bar	15 Bar	15 Bar
Dia. of Shell (OD)	300 mm	350 mm	400 mm	300 mm	350 mm	400 mm	300 mm	350 mm	400 mm
Operating Temperature	+5°C to +60°C	+5°C to +60°C	+5°C to +60°C	+5°C to +60°C	+5°C to +60°C	+5°C to +60°C	+5°C to +60°C	+5°C to +60°C	+5°C to +60°C
Hydrostatic Test Pressure	30 Bar	30 Bar	30 Bar	30 Bar	30 Bar	30 Bar	30 Bar	30 Bar	30 Bar
Body Thickness	1.8 mm	2 mm	2 mm	1.8 mm	2 mm	2 mm	1.8 mm	2 mm	2 mm

## TETRAQUAD

### OVERVIEW:

Ceasefire TetraQuad is a mini tender on wheels. A power-packed Watermist + Foam system that quadruples the firefighting power by four. TetraQuad's firefighting might come from its four state-of-the-art multi-rotors working in sync with each of the four 62.5 ltr containers [totaling 250 ltrs in capacity].

### FEATURES:

- Works on class A and B fires.
- Low pressure, safe technology.
- 4 Cylinders, Massive Firefighting.
- Easy-to-use with quick activation.
- Environment-friendly.
- Two modes of firefighting - Jet & Spray Mode.

FIGHTS CLASS

CERTIFICATIONS

A B



Scan the QR code to know more about the product

### TECHNICAL SPECIFICATIONS: TETRAQUAD

Nomenclature	Tetraquad Fire Extinguisher 250L SS SP Red	Tetraquad Fire Extinguisher 250L SS SP Red Additive
Stored Pressure / Cartridge	Stored Pressure	Stored Pressure
Agent	Water	Water + 6% of KV Lite Foam 3% C-6
Throw (min.)	Jet Mode : 20 meters   Spray Mode : 4 Meters	Jet Mode : 20 meters   Spray Mode : 4 Meters
Product Code	CF-000860	CF-000861
Certification type	PED, UKCA-PED	PED, UKCA-PED
PED	Yes	Yes
UKCA-PED	Yes	Yes
Gross Weight (approx.)	500 kg	500 kg
Net Mass (approx.)	250 ltr	250 ltr
Discharge Mechanism	Operating Lever (Ball Valve)	Operating Lever (Ball Valve)
Can Construction	Drawn Rolled & MIG Welded	Drawn Rolled & MIG Welded
Valve / Cap Construction	Forging & Machining	Forging & Machining
External Coating	Epoxy Polyester Powder	Epoxy Polyester Powder
Warranty in Year	1	1
Min. Discharge Time	100 to 200 sec	100 to 200 sec
Working Pressure	12 to 15 Bar	12 to 15 Bar
Dia. of Shell (OD)	450 mm	450 mm
Operating Temperature	+5°C to +60°C	+5°C to +60°C
Hydrostatic Test Pressure	30 Bar	30 Bar
Body Thickness	2.5 mm	2.5 mm





## WET CHEMICAL PORTABLE EXTINGUISHERS

### OVERVIEW:

In commercial kitchens, the liberal use of fire and the presence of combustible substances make it easy for a fire to flare up. Designed to fight kitchen oil and fat fires, Ceasefire's Wet Chemical fire extinguisher uses an environmental friendly foaming agent that blankets the flames, cuts off the supply of oxygen and cools the oil to below the self-ignition point.

### FEATURES:

- Fights class A, F and Electrically started fires.
- Bio-degradable extinguishing agent.
- Reduces risk of re-ignition.
- Epoxy polyester powder coated internal container lining.
- Suitable for use on live electrical equipment upto 1000 V from a distance of 1 meter.
- Equipped with Schraeder Valve and Pressure Relief Valve.



Scan the QR code to know more about the product

### TECHNICAL SPECIFICATIONS: WET CHEMICAL EXTINGUISHERS

Nomenclature	Fire Ext Wet Chemical 3L MS SP Red	Fire Ext Wet Chemical 3L SS SP Red	Fire Ext Wet Chemical 6L MS SP Red	Fire Ext Wet Chemical 6L SS SP Red	Fire Ext Wet Chemical 9L MS SP Red	Fire Ext Wet Chemical 9L SS SP Red
Stored Pressure/Cartridge	Stored Pressure	Stored Pressure	Stored Pressure	Stored Pressure	Stored Pressure	Stored Pressure
Agent	KV Lite 100% Class K Foam	KV Lite 100% Class K Foam	KV Lite 100% Class K Foam	KV Lite 100% Class K Foam	KV Lite 100% Class K Foam	KV Lite 100% Class K Foam
Throw (min.)	3 meters	3 meters	3 meters	3 meters	3 meters	3 meters
Product Code	CF-000800*	CF-000780*	CF-000801*	CF-000719*	CF-000802*	CF-000720*
Certification type	BS EN3, PED, UKCA-PED, EU-MED, UKCA-MER	BS EN3, PED, UKCA-PED, EU-MED, UKCA-MER	BS EN3, PED, UKCA-PED, EU-MED, UKCA-MER	BS EN3, PED, UKCA-PED, EU-MED, UKCA-MER	BS EN3, PED, UKCA-PED, EU-MED, UKCA-MER	BS EN3, PED, UKCA-PED, EU-MED, UKCA-MER
LPCB	Yes	Yes	Yes	Yes	Yes	Yes
Kitemark	Yes	Yes	Yes	Yes	Yes	Yes
PED	Yes	Yes	Yes	Yes	Yes	Yes
UKCA-PED	Yes	Yes	Yes	Yes	Yes	Yes
EU-MED	Yes	Yes	Yes	Yes	Yes	Yes
UKCA-MER	Yes	Yes	Yes	Yes	Yes	Yes
Gross Weight (approx.)	6.3 kg	7.1 kg	11.60 kg	12.3 kg	16.9 kg	17.4 kg
Net Mass (approx.)	3 Ltr	3 Ltr	6 Ltr	6 Ltr	9 Ltr	9 Ltr
Height of Fire Ext.(approx)	435 mm	435 mm	520 mm	520 mm	615 mm	610 mm
Discharge Mechanism	Squeeze Grip	Squeeze Grip	Squeeze Grip	Squeeze Grip	Squeeze Grip	Squeeze Grip
Fire Ratings	8A   40F	8A   40F	13A   75F	13A   75F	21A   75F	21A   75F
Can Construction	Deep Drawn & MIG Welded	Drawn Rolled & MIG Welded	Deep Drawn & MIG Welded	Drawn Rolled & MIG Welded	Deep Drawn & MIG Welded	Drawn Rolled & MIG Welded
Valve/Cap Construction	Forging & Machining	Forging & Machining	Forging & Machining	Forging & Machining	Forging & Machining	Forging & Machining
External Coating	Epoxy Polyester Powder	Epoxy Polyester Powder	Epoxy Polyester Powder	Epoxy Polyester Powder	Epoxy Polyester Powder	Epoxy Polyester Powder
Warranty in Years	5	5	5	5	5	5
Min. Discharge Time	9 sec	9 sec	9 sec	9 sec	9 sec	9 sec
Working Pressure	15 Bar	15 Bar	15 Bar	15 Bar	15 Bar	15 Bar
Dia. of Shell (OD)	140 mm	140 mm	160 mm	160 mm	175 mm	175 mm
Operating Temperature	+5°C to +60°C	+5°C to +60°C	+5°C to +60°C	+5°C to +60°C	+5°C to +60°C	+5°C to +60°C
Hydrostatic Test Pressure	35 Bar	35 Bar	35 Bar	35 Bar	35 Bar	35 Bar
Body Thickness	1.2 mm	1.5 mm	1.4 mm	1.5 mm	1.4 mm	1.5 mm
Schraeder Valve	Yes	Yes	Yes	Yes	Yes	Yes
Pressure relief valve	Yes	Yes	Yes	Yes	Yes	Yes

\* Available with additional hanging bracket.

## TECHNICAL SPECIFICATIONS: WET CHEMICAL PORTABLE EXTINGUISHERS [CHROME FINISH]

Nomenclature	Fire Ext Wet Chemical 3L SS SP Chrome	Fire Ext Wet Chemical 6L SS SP Chrome	Fire Ext Wet Chemical 9L SS SP Chrome
Stored Pressure/Cartridge	Stored Pressure	Stored Pressure	Stored Pressure
Agent	KV Lite 100% Class K Foam	KV Lite 100% Class K Foam	KV Lite 100% Class K Foam
Throw (min.)	3 meters	3 meters	3 meters
Product Code	CF-001180**	CF-001181**	CF-001182**
Certification type	BS EN3, PED, UKCA-PED	BS EN3, PED, UKCA-PED	BS EN3, PED, UKCA-PED
LPCB	Yes*	Yes*	Yes*
Kitemark	No	No	No
PED	Yes	Yes	Yes
UKCA-PED	Yes	Yes	Yes
EU-MED	No	No	No
UKCA-MER	No	No	No
Gross Weight (approx.)	7.10 kg	12.30 kg	16.50 kg
Net Mass (approx.)	3 Ltr	6 Ltr	9 Ltr
Height of Fire Ext.(approx)	435 mm	520 mm	610 mm
Discharge Mechanism	Squeeze Grip	Squeeze Grip	Squeeze Grip
Fire Ratings	8A   40F	13A   75F	21A   75F
Can Construction	Drawn Rolled & MIG Welded	Drawn Rolled & MIG Welded	Drawn Rolled & MIG Welded
Valve/Cap Construction	Forging & Machining	Forging & Machining	Forging & Machining
External Coating	Chrome Finish	Chrome Finish	Chrome Finish
Warranty in Years	5	5	5
Min. Discharge Time	9 sec	9 sec	9 sec
Working Pressure	15 Bar	15 Bar	15 Bar
Dia. of Shell (OD)	140 mm	160 mm	175 mm
Operating Temperature	+5°C to +60°C	+5°C to +60°C	+5°C to +60°C
Hydrostatic Test Pressure	35 Bar	35 Bar	35 Bar
Body Thickness	1.5 mm	1.5 mm	1.5 mm
Schraeder Valve	Yes	Yes	Yes
Pressure relief valve	Yes	Yes	Yes

\* Technical approval to EN 3 except EN 3-7 clause 16.1 LPCB ref 1329g.

\*\* Available with additional hanging bracket.





## FLUOROKETONE PORTABLE EXTINGUISHERS

### OVERVIEW:

Short circuits in the electrical mains or in sensitive electronic equipment are the most common causes of home and office fires. Powder extinguishers can extinguish these, but they also cause serious collateral damage. Ceasefire's Clean Agent extinguisher is armed with cutting-edge clean agent Fluoroketone which ensures the fire is put out and expensive equipment is rendered damage free.

### FEATURES:

- Fluoroketone is not part of the F-Gas Regulations.
- Fights class A, B, C and Electrically started fires.
- Zero collateral damage and residue-free.
- Magnetic Pressure Gauge.
- Safe Low Pressure Technology that does not displace oxygen in the fire zone.
- Zero Ozone Depletion Potential (ODP).
- Safe to use in confined areas.



Scan the QR code to know more about the product

### TECHNICAL SPECIFICATIONS: FLUOROKETONE (FK) EXTINGUISHERS

Nomenclature	Fire Ext 2Kg MS SP Red	Fire Ext 4Kg MS SP Red	Fire Ext 6Kg MS SP Red	Fire Ext 9Kg MS SP Red
Agent	Fluoroketone (FK- 5-1-12)	Fluoroketone (FK- 5-1-12)	Fluoroketone (FK- 5-1-12)	Fluoroketone (FK- 5-1-12)
Throw (min.)	3 meters	4 meters	4 meters	4 meters
Product Code	CF-001333*	CF-001334*	CF-001335*	CF-001336*
Certification type	BS EN3, PED, UKCA-PED	BS EN3, PED, UKCA-PED	BS EN3, PED, UKCA-PED	PED, UKCA-PED
LPCB	Yes	Yes	Yes	No
PED	Yes	Yes	Yes	Yes
UKCA-PED	Yes	Yes	Yes	Yes
Gross Weight (approx.)	3.75 kg	6.90 kg	9.50 kg	14.70 kg
Net Mass (approx.)	2 kg	4 kg	6 kg	9 kg
Height of Fire Ext.(approx)	370 mm	440 mm	485 mm	615 mm
Discharge Mechanism	Thumb Triggered	Squeeze Grip	Squeeze Grip	Squeeze Grip
Fire Ratings	21B	34B	34B	55B
Valve/Cap Construction	Forging & Machining	Forging & Machining	Forging & Machining	Forging & Machining
External Coating	Epoxy Polyester Powder Coating	Epoxy Polyester Powder Coating	Epoxy Polyester Powder Coating	Epoxy Polyester Powder Coating
Warranty in Years	5	5	5	5
Min. Discharge Time	6 sec	6 sec	6 sec	9 sec
Working Pressure	10 Bar	10 Bar	10 Bar	10 Bar
Dia. of Shell (OD)	108 mm	140 mm	160 mm	175 mm
Operating Temperature	-30°C to +60°C	-30°C to +60°C	-30°C to +60°C	-30°C to +60°C
Hydrostatic Test Pressure	35 Bar	35 Bar	35 Bar	35 Bar
Body Thickness	1.6 mm	1.6 mm	1.6 mm	2 mm
Schraeder Valve	No	Yes	Yes	Yes
Pressure relief valve	No	Yes	Yes	Yes

\* Available with additional hanging bracket.

## B PLUS SPECIAL APPLICATION (CLASS B) EXTINGUISHERS

### OVERVIEW:

Ceasefire's B Plus quadruples the power of a conventional extinguisher! It's the perfect extinguisher for petrol stations and petrochemical plants. The Ceasefire B Plus is ideal for Class B and C fires involving gasoline, alcohol, industrial chemicals, and more. When activated, its unique powder splits into four, covering a large surface area. So when faced with a high risk of class B fires like petrol, diesel, etc. You go for B Plus.

### FEATURES:

- Fights Class B, C and Electrically started fires.
- Unique powder splits into four upon activation.
- High power agent throw covers a huge surface area.
- Equipped with Schraeder Valve and Pressure Relief Valve.



Scan the QR code to know more about the product

### TECHNICAL SPECIFICATIONS: B PLUS EXTINGUISHERS

Nomenclature	Fire Ext 2Kg MS SP Red	Fire Ext 4Kg MS SP Red	Fire Ext 6Kg MS SP Red	Fire Ext 9Kg MS SP Red
Agent	B Plus Powder	B Plus Powder	B Plus Powder	B Plus Powder
Throw (min.)	4 meters	6 meters	7 meters	7 meters
Product Code	CF-000736*	CF-000737*	CF-000738*	CF-000739*
Certification type	BS EN3, PED, UKCA-PED	BS EN3, PED, UKCA-PED	BS EN3, PED, UKCA-PED, EU-MED, UKCA-MER	BS EN3, PED, UKCA-PED, EU-MED, UKCA-MER
LPCB	Yes	Yes	Yes	Yes
Kitemark	Yes	Yes	Yes	Yes
PED	Yes	Yes	Yes	Yes
UKCA-PED	Yes	Yes	Yes	Yes
EU-MED	No	No	Yes	Yes
UKCA-MER	No	No	Yes	Yes
Gross Weight (approx.)	4.3 kg	7.3 kg	10.3 kg	14.3 kg
Net Mass (approx.)	2 kg	4 kg	6 kg	9 kg
Height of Fire Ext.(approx)	440 mm	485 mm	615 mm	615 mm
Discharge Mechanism	Squeeze Grip	Squeeze Grip	Squeeze Grip	Squeeze Grip
Fire Ratings	89B	233B	233B	233B
Can Construction	Deep Drawn & MIG Welded	Deep Drawn & MIG Welded	Deep Drawn & MIG Welded	Deep Drawn & MIG Welded
Valve/Cap Construction	Forging & Machining	Forging & Machining	Forging & Machining	Forging & Machining
External Coating	Epoxy Polyester Powder	Epoxy Polyester Powder	Epoxy Polyester Powder Coating	Epoxy Polyester Powder Coating
Warranty in Years	5	5	5	5
Min. Discharge Time	13 sec	15 sec	19 sec	24 sec
Working Pressure	15 Bar	15 Bar	15 Bar	15 Bar
Dia. of Shell (OD)	140 mm	160 mm	175 mm	204 mm
Operating Temperature	-30°C to +60°C	-30°C to +60°C	-30°C to +60°C	-30°C to +60°C
Hydrostatic Test Pressure	35 Bar	35 Bar	35 Bar	35 Bar
Body Thickness	1.2 mm	1.4 mm	1.4 mm	1.6 mm
Schraeder Valve	Yes	Yes	Yes	Yes
Pressure relief valve	Yes	Yes	Yes	Yes

\* Available with additional hanging bracket.

## METAL FIRE EXTINGUISHERS

### OVERVIEW:

Industries that work with metals such as magnesium, potassium, sodium, titanium, uranium and calcium are at a high risk of fire. Using the wrong extinguishing agent in this case may cause more damage. The Ceasefire SPM-TEC and SPM-PYRO are ideal combatants against fires involving heavy metals, alkali metals and their alloys. They are powerful enough to stop metal fires of up to 5000°C. Dead in their tracks. Within minutes.

### FEATURES:

- Fights class D fire.
- Deep drawn mild steel container.
- Powder Coated cylinder liner.
- Special Cascade Nozzle to aid effective agent dispersal over fire.
- Equipped with Schraeder Valve and Pressure Relief Valve.
- SPM-TEC effectively fights light metal fires like Magnesium [Mg], Lithium [Li], Sodium [Na], Potassium [K], etc. which produce heat up to 2000°C.
- SPM-PYRO effectively fights heavy metal fires like Plutonium [Pl], Titanium [Ti], Lead [Pb], Zinc [Zn], Copper [Cu], etc. which produces heat up to 5000°C or above.



FIGHTS CLASS CERTIFICATIONS

D

CE 1128 UK CA

### TECHNICAL SPECIFICATIONS: METAL FIRE EXTINGUISHERS

Nomenclature	Metal Fire Ext 4kg MS SP Red SPM TEC	Metal Fire Ext 6kg MS SP Red SPM TEC	Metal Fire Ext 9kg MS SP Red SPM TEC	Metal Fire Ext 4kg MS SP Red SPM PYRO	Metal Fire Ext 6kg MS SP Red SPM PYRO	Metal Fire Ext 9kg MS SP Red SPM PYRO
Stored Pressure/Cartridge	Stored Pressure	Stored Pressure	Stored Pressure	Stored Pressure	Stored Pressure	Stored Pressure
Agent	SPM TEC	SPM TEC	SPM TEC	SPM PYRO	SPM PYRO	SPM PYRO
Product Code	CF-000043	CF-000044	CF-000045	CF-000040	CF-000041	CF-000042
Certification type	PED, UKCA-PED	PED, UKCA-PED	PED, UKCA-PED	PED, UKCA-PED	PED, UKCA-PED	PED, UKCA-PED
PED	Yes	Yes	Yes	Yes	Yes	Yes
UKCA-PED	Yes	Yes	Yes	Yes	Yes	Yes
Gross Weight (approx.)	7.2 kg	9.65 kg	14.05 kg	7.2 kg	9.65 kg	14.05 kg
Net Mass (approx.)	4 kg	6 kg	9 kg	4 kg	6 kg	9 kg
Height of Fire Ext.(approx)	440 mm	485 mm	615 mm	440 mm	485 mm	615 mm
Discharge Mechanism	Squeeze Grip	Squeeze Grip	Squeeze Grip	Squeeze Grip	Squeeze Grip	Squeeze Grip
Can Construction	Deep Drawn & MIG Welded	Deep Drawn & MIG Welded	Deep Drawn & MIG Welded	Deep Drawn & MIG Welded	Deep Drawn & MIG Welded	Deep Drawn & MIG Welded
Valve/Cap Construction	Forging & Machining	Forging & Machining	Forging & Machining	Forging & Machining	Forging & Machining	Forging & Machining
External Coating	Epoxy Polyester Powder	Epoxy Polyester Powder	Epoxy Polyester Powder	Epoxy Polyester Powder	Epoxy Polyester Powder	Epoxy Polyester Powder
Warranty in Years	5	5	5	5	5	5
Min. Discharge Time	15 sec	16 sec	18 sec	15 sec	16 sec	18 sec
Working Pressure	15 Bar	15 Bar	15 Bar	15 Bar	15 Bar	15 Bar
Dia. of Shell (OD)	140 mm	160 mm	175 mm	140 mm	160 mm	175 mm
Operating Temperature	-30°C to +60°C	-30°C to +60°C	-30°C to +60°C	-30°C to +60°C	-30°C to +60°C	-30°C to +60°C
Hydrostatic Test Pressure	35 Bar	35 Bar	35 Bar	35 Bar	35 Bar	35 Bar
Body Thickness	1.2 mm	1.4 mm	1.4 mm	1.2 mm	1.4 mm	1.4 mm
Schraeder Valve	Yes	Yes	Yes	Yes	Yes	Yes
Pressure relief valve	Yes	Yes	Yes	Yes	Yes	Yes

### Metal Fire Extinguishers [SPM - Tec]



Scan the QR code to know more about the product

### Metal Fire Extinguishers [SPM - Pyro]



Scan the QR code to know more about the product



# Automatic Extinguishers

24X7 Automated Fire Protection

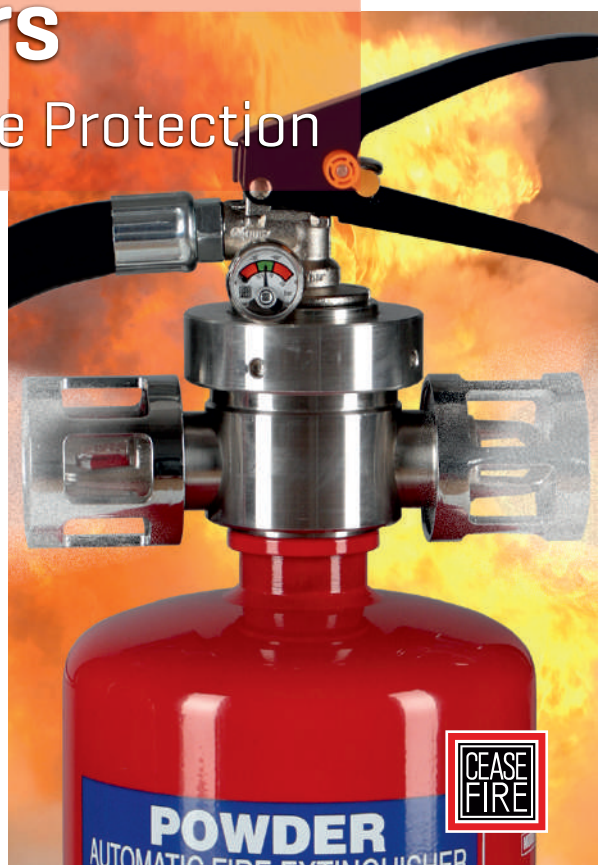



# AUTOMATIC FIRE EXTINGUISHERS (WALL MOUNTED)

## OVERVIEW:

Ceasefire's Inverted Automatic Fire Extinguisher addresses two simple problems; first of fire safety and second of space crunch. Being an automatic extinguisher it is ideal for spaces like boats and engine compartments that are not just prone to fire but also have limited space, where installing an extinguisher can be a challenge.

## FEATURES:

- Comes in option of Fluoroketone and Powder.
- Clean agent Fluoroketone extinguishers do not fall under the F-gas regulations.
- Works on all classes of fire.
- Automatic detection and suppression.
- Comes with a secure mounting bracket for direct installation on the wall.
- Optional flexible mounting bracket that enables optimal positioning of the extinguisher in the risk zone.
- Fluoroketone extinguishers safe to use in confined areas.



## TECHNICAL SPECIFICATIONS: FLUOROKETONE (FK) AUTOMATIC EXTINGUISHERS

Nomenclature	Automatic Fire Ext 1Kg MS SP Red	Automatic Fire Ext 1.5Kg MS SP Red	Automatic Fire Ext 2Kg MS SP Red	Automatic Fire Ext 2.5Kg MS SP Red	Automatic Fire Ext 4Kg MS SP Red	Automatic Fire Ext 6Kg MS SP Red	Automatic Fire Ext 9Kg MS SP Red
Agent	Fluoroketone (FK-5-1-12)	Fluoroketone (FK-5-1-12)	Fluoroketone (FK-5-1-12)	Fluoroketone (FK-5-1-12)	Fluoroketone (FK-5-1-12)	Fluoroketone (FK-5-1-12)	Fluoroketone (FK-5-1-12)
Product Code	CF-001411	CF-001412	CF-001413	CF-001414	CF-001415	CF-001416	CF-001417
Certification type	PED, UKCA-PED	PED, UKCA-PED	PED, UKCA-PED	PED, UKCA-PED	PED, UKCA-PED	PED, UKCA-PED	PED, UKCA-PED
PED	Yes	Yes	Yes	Yes	Yes	Yes	Yes
UKCA-PED	Yes	Yes	Yes	Yes	Yes	Yes	Yes
Gross Weight (approx.)	1.8 kg	2.8 kg	3.3 kg	4.1 kg	6 kg	8.7 kg	12.9 kg
Net Mass (approx.)	1 kg	1.5 kg	2 kg	2.5 kg	4 kg	6 kg	9 kg
Maximum Volume Covered*	1.4 m <sup>3</sup>	2.1 m <sup>3</sup>	2.8 m <sup>3</sup>	3.5 m <sup>3</sup>	5.7 m <sup>3</sup>	8.5 m <sup>3</sup>	12.8 m <sup>3</sup>
Height of Fire Ext.(approx)	330 mm	350 mm	350 mm	290 mm	396 mm	446 mm	577 mm
Discharge Mechanism	Automatic QBD**	Automatic QBD**	Automatic QBD**	Automatic QBD**	Automatic QBD**	Automatic QBD**	Automatic QBD**
Can Construction	Deep Drawn & MIG Welded	Deep Drawn & MIG Welded	Deep Drawn & MIG Welded	Deep Drawn & MIG Welded	Deep Drawn & MIG Welded	Deep Drawn & MIG Welded	Deep Drawn & MIG Welded
Valve/Cap Construction	Forging & Machining	Forging & Machining	Forging & Machining	Forging & Machining	Forging & Machining	Forging & Machining	Forging & Machining
External Coating	Epoxy Polyester Powder	Epoxy Polyester Powder	Epoxy Polyester Powder	Epoxy Polyester Powder	Epoxy Polyester Powder	Epoxy Polyester Powder	Epoxy Polyester Powder
Warranty in Years	5	5	5	5	5	5	5
Min. Discharge Time	0.5 sec	0.6 sec	1 sec	1 sec	2 sec	3 sec	4 sec
Working Pressure	10 Bar	10 Bar	10 Bar	10 Bar	10 Bar	10 Bar	10 Bar
Dia. of Shell (OD)	86.5 mm	108 mm	108 mm	140 mm	140 mm	160 mm	175 mm
Operating Temp.	-30°C to +60°C	-30°C to +60°C	-30°C to +60°C	-30°C to +60°C	-30°C to +60°C	-30°C to +60°C	-30°C to +60°C
Hydrostatic Test Pressure	30 Bar	30 Bar	30 Bar	30 Bar	30 Bar	30 Bar	30 Bar
Body Thickness	1.6 mm	1.6 mm	1.6 mm	1.6 mm	1.6 mm	1.6 mm	2 mm

\*Maximum height of the extinguisher from the floor: 3.6 m.

## \*\*QUARTZOID BULB KEY (QBD)

- 57°C / 135°F
- 68°C / 155°F
- 79°C / 174°F
- 93°C / 200°F
- 141°C / 286°F
- 182°C / 360°F
- 227°C / 440°F

## Fluoroketone Extinguishers (FK-5-1-12)

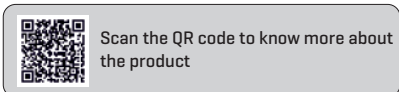



**TECHNICAL SPECIFICATIONS: ABC POWDER MAP 50 AUTOMATIC EXTINGUISHERS**

Nomenclature	Automatic Fire Ext 1Kg MS SP Red	Automatic Fire Ext 2Kg MS SP Red	Automatic Fire Ext 4Kg MS SP Red	Automatic Fire Ext 6Kg MS SP Red	Automatic Fire Ext 9Kg MS SP Red
Agent	ABC Powder MAP 50	ABC Powder MAP 50	ABC Powder MAP 50	ABC Powder MAP 50	ABC Powder MAP 50
Product Code	CF-001401	CF-001402	CF-001403	CF-001404	CF-001405
Certification type	PED, UKCA-PED	PED, UKCA-PED	PED, UKCA-PED	PED, UKCA-PED	PED, UKCA-PED
PED	Yes	Yes	Yes	Yes	Yes
UKCA-PED	Yes	Yes	Yes	Yes	Yes
Gross Weight (approx.)	1.8 kg	3.3 kg	6 kg	8.7 kg	12.9 kg
Net Mass (approx.)	1 kg	2 kg	4 kg	6 kg	9 kg
Height of Fire Ext.(approx)	330 mm	350 mm	396 mm	446 mm	577 mm
Maximum Area Covered*	1.6 m <sup>2</sup>	2.3 m <sup>2</sup>	6.3 m <sup>2</sup>	9.8 m <sup>2</sup>	19.2 m <sup>2</sup>
Discharge Mechanism	Automatic QBD**	Automatic QBD**	Automatic QBD**	Automatic QBD**	Automatic QBD**
Can Construction	Deep Drawn & MIG Welded	Deep Drawn & MIG Welded	Deep Drawn & MIG Welded	Deep Drawn & MIG Welded	Deep Drawn & MIG Welded
Valve/Cap Construction	Forging & Machining	Forging & Machining	Forging & Machining	Forging & Machining	Forging & Machining
External Coating	Epoxy Polyester Powder	Epoxy Polyester Powder	Epoxy Polyester Powder	Epoxy Polyester Powder	Epoxy Polyester Powder
Warranty in Years	5	5	5	5	5
Min. Discharge Time	1 sec	1.2 sec	2.5 sec	3.5 sec	5 sec
Working Pressure	15 Bar	15 Bar	15 Bar	15 Bar	15 Bar
Dia. of Shell (OD)	86.5 mm	108 mm	140 mm	160 mm	175 mm
Operating Temp.	-30°C to +60°C	-30°C to +60°C	-30°C to +60°C	-30°C to +60°C	-30°C to +60°C
Hydrostatic Test Pressure	30 Bar	30 Bar	30 Bar	30 Bar	30 Bar
Body Thickness	1.6 mm	1.6 mm	1.6 mm	1.6 mm	2 mm

\*Maximum room height for 1 kg - 1.5 m, 2 kg - 2 m, 4 kg - 3.2 m, 6 kg - 3.2 m, 9 kg - 3.2 m.

**\*\*QUARTZOID BULB KEY (QBD)**

- 57°C / 135°F
- 68°C / 155°F
- 79°C / 174°F
- 93°C / 200°F
- 141°C / 286°F
- 182°C / 360°F
- 227°C / 440°F

**TELESCOPING WALL MOUNTING BRACKET**

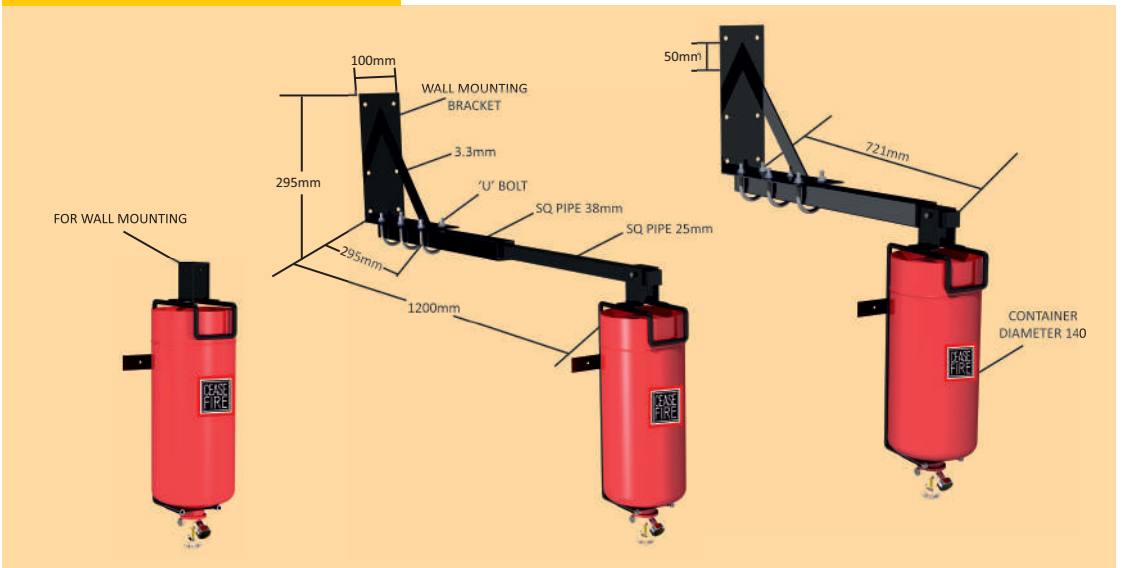

**ABC Powder Extinguishers [MAP 90]**

Scan the QR code to know more about the product

## AUTOMATIC FIRE EXTINGUISHERS (CEILING MOUNTED)

### OVERVIEW:

There are areas in a workplace that contain highly flammable materials with little or no human traffic. Here, the chances of fire going undetected are high. Ceasefire's Ceiling mounted extinguisher detects the rising temperature of the area and activates automatically, even when there's no one around, ensuring that the fire is brought under control early and efficiently.

### FEATURES:

- Fights class A, B, C and Electrically started fires.
- Automatic discharge mechanism.
- Rigid ceiling mount.
- Comes in option of Fluoroketone and Powder.
- Green Technology.
- Fluoroketone extinguishers safe to use in confined areas.



Tested by **bsi.**



### TECHNICAL SPECIFICATIONS: CEILING MOUNTED AUTOMATIC EXTINGUISHERS

Nomenclature	Ceiling Mounted 5Kg MS SP Red	Ceiling Mounted 10Kg MS SP Red	Ceiling Mounted 5Kg MS SP Red	Ceiling Mounted 10Kg MS SP Red
Stored Pressure/Cartridge	Stored Pressure	Stored Pressure	Stored Pressure	Stored Pressure
Agent	MAP 90	MAP 90	Fluoroketone (FK- 5-1-12)	Fluoroketone (FK- 5-1-12)
Product Code	CF-000017	CF-000018	CF-001337	CF-001338
Certification type	PED, UKCA-PED, BSI Tested	PED, UKCA-PED, BSI Tested	PED, UKCA-PED, BSI Tested	PED, UKCA-PED, BSI Tested
PED	Yes	Yes	Yes	Yes
UKCA-PED	Yes	Yes	Yes	Yes
Gross Weight (approx.)	7.8 kg	14.9 kg	7.8 kg	14.9 kg
Net Mass (approx.)	5 kg	10 kg	5 kg	10 kg
Height of Fire Ext.(approx) with base	332.5 mm	362.5 mm	332.5 mm	362.5 mm
Maximum Area*/Volume Covered	upto 12 m <sup>2</sup>	upto 28 m <sup>2</sup>	7 m <sup>3</sup>	15 m <sup>3</sup>
Discharge Mechanism	Automatic QBD**	Automatic QBD**	Automatic QBD**	Automatic QBD**
Can Construction	Deep Drawn & MIG Welded	Deep Drawn & MIG Welded	Deep Drawn & MIG Welded	Deep Drawn & MIG Welded
Valve/Cap Construction	Forging & Machining	Forging & Machining	Forging & Machining	Forging & Machining
External Coating	Epoxy Polyester Powder	Epoxy Polyester Powder	Epoxy Polyester Powder	Epoxy Polyester Powder
Warranty in Years	5	5	5	5
Min. Discharge Time	4 to 8 sec	6 to 10 sec	4 to 8 sec	6 to 10 sec
Working Pressure	15 Bar	15 Bar	10 Bar	10 Bar
Dia. of Shell (OD)	240 mm	300 mm	240 mm	300 mm
Operating Temp.	-30°C to +60°C	-30°C to +60°C	-30°C to +60°C	-30°C to +60°C
Hydrostatic Test Pressure	35 Bar	35 Bar	35 Bar	35 Bar
Body Thickness	1.6 mm	2 mm	1.6 mm	2 mm

\*Maximum ceiling height 5kg - 3.6 m, 10kg - 4.4 m.

### \*\*QUARTZOID BULB KEY (QBD)

- 57°C / 135°F
- 68°C / 155°F
- 79°C / 174°F
- 93°C / 200°F
- 141°C / 286°F
- 182°C / 360°F
- 227°C / 440°F

### ABC Powder Extinguishers (MAP 90)

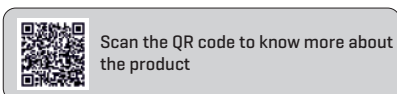

### Fluoroketone Extinguishers (FK-5-1-12)

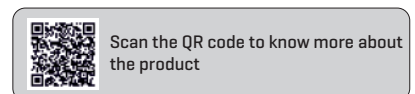



# Ceasefire Mini

The Biggest, Smallest  
Firefighter.



# CEASEFIRE MINI

## OVERVIEW:

The Mini is Ceasefire's state-of-the-art micro-environment suppression system. Palm-sized, it sits snugly inside small enclosed spaces that are vulnerable to fire. When the temperature of the micro-environment exceeds a preset limit, the Mini swings into action and extinguishes the fire. Servers, fuse boxes; the Mini fits anywhere, and protects everywhere.

## FEATURES:

- > Fights all classes of fire.
- > Self-activated and easy to install.
- > Clean agent Fluoroketone based extinguishers do not fall under the F-gas regulations.
- > No power supply required.
- > Heat-sensitive glass bulb acts as a heat sensor and actuator.
- > Mini is based on an environment friendly extinguishing agent Fluoroketone.
- > Safe to use in confined areas.



### Types of Mini:

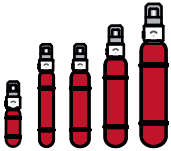

#### Intuitive System

The Mini Intuitive System is a direct suppression system, which protects the micro-environment from enclosed area inside. Place it inside, or attach it to the inner wall of the micro-environment, and the Mini is ready to protect.

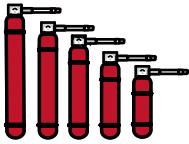
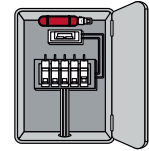

#### Adaptive System

The Mini Adaptive System is an indirect suppression system designed for those micro-environments which are too small to even accommodate a Mini, let alone other firefighting systems. In this case, the Mini container is installed on the outside, with its heat-sensitive glass bulb inside the micro-environment.

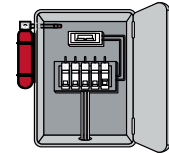

Tested by **bsi.**



Scan the QR code to know more about the product



**TECHNICAL SPECIFICATIONS: MINI INTUITIVE AUTOMATIC EXTINGUISHERS**

Nomenclature	Mini Intuitive Automatic Fire Ext 100gm SS SP Red	Mini Intuitive Automatic Fire Ext 200gm SS SP Red	Mini Intuitive Automatic Fire Ext 300gm SS SP Red	Mini Intuitive Automatic Fire Ext 400gm SS SP Red	Mini Intuitive Automatic Fire Ext 500gm SS SP Red
Stored Pressure/Cartridge	Stored Pressure	Stored Pressure	Stored Pressure	Stored Pressure	Stored Pressure
Agent	Fluoroketone (FK- 5-1-12)	Fluoroketone (FK- 5-1-12)	Fluoroketone (FK- 5-1-12)	Fluoroketone (FK- 5-1-12)	Fluoroketone (FK- 5-1-12)
Product Code	CF-001339A	CF-001341A	CF-001343A	CF-001345A	CF-001347A
Certification type	PED, UKCA-PED, BSI Tested	PED, UKCA-PED, BSI Tested	PED, UKCA-PED, BSI Tested	PED, UKCA-PED, BSI Tested	PED, UKCA-PED, BSI Tested
PED	Yes	Yes	Yes	Yes	Yes
UKCA-PED	Yes	Yes	Yes	Yes	Yes
Gross Weight (approx.)	0.665 Kg	0.90 kg	1.10 Kg	1.25 Kg	1.45 Kg
Net Mass (approx.)	100 Gm	200 Gm	300 Gm	400 Gm	500 Gm
Total Height of Fire Ext. (approx)	184 mm	284 mm	276 mm	331 mm	386 mm
Maximum Volume Covered*	0.130 m <sup>3</sup>	0.260 m <sup>3</sup>	0.290 m <sup>3</sup>	0.520 m <sup>3</sup>	0.650 m <sup>3</sup>
Discharge Mechanism	Automatic QBD**	Automatic QBD**	Automatic QBD**	Automatic QBD**	Automatic QBD**
Can Construction	Deep Drawn & MIG Welded	Deep Drawn & MIG Welded	Deep Drawn & MIG Welded	Deep Drawn & MIG Welded	Deep Drawn & MIG Welded
Valve/Cap Construction	Machining	Machining	Machining	Machining	Machining
External Coating	Epoxy Polyester Powder	Epoxy Polyester Powder	Epoxy Polyester Powder	Epoxy Polyester Powder	Epoxy Polyester Powder
Warranty in Years	5	5	5	5	5
Min. Discharge Time	1 to 3 sec	1 to 3 sec	1 to 3 sec	1 to 3 sec	1 to 3 sec
Working Pressure	10 Bar / 12 Bar	10 Bar / 12 Bar	10 Bar / 12 Bar	10 Bar / 12 Bar	10 Bar / 12 Bar
Dia. of Shell (OD)	40 mm	40 mm	50 mm	50 mm	50 mm
Operating Temp.	-30°C to +60°C	-30°C to +60°C	-30°C to +60°C	-30°C to +60°C	-30°C to +60°C
Hydrostatic Test Pressure	35 Bar	35 Bar	35 Bar	35 Bar	35 Bar
Body Thickness	1.2 mm	1.2 mm	1.2 mm	1.2 mm	1.2 mm

\*Ideally be placed 0 to 150 mm from the ceiling of the enclosed area.

**\*\*QUARTZOID BULB KEY (QBD)**

- 57°C / 135°F
- 68°C / 155°F
- 79°C / 174°F
- 93°C / 200°F
- 141°C / 286°F
- 182°C / 360°F
- 227°C / 440°F





**TECHNICAL SPECIFICATIONS: MINI ADAPTIVE AUTOMATIC EXTINGUISHERS WITH 50mm BARREL**

Nomenclature	Mini Adaptive Automatic Fire Ext 100gm SS SP Red w/50mm barrel	Mini Adaptive Automatic Fire Ext 200gm SS SP Red w/50mm barrel	Mini Adaptive Automatic Fire Ext 300gm SS SP Red w/50mm barrel	Mini Adaptive Automatic Fire Ext 400gm SS SP Red w/50mm barrel	Mini Adaptive Automatic Fire Ext 500gm SS SP Red w/50mm barrel
Stored Pressure/Cartridge	Stored Pressure	Stored Pressure	Stored Pressure	Stored Pressure	Stored Pressure
Agent	Fluoroketone (FK- 5-1-12)	Fluoroketone (FK- 5-1-12)	Fluoroketone (FK- 5-1-12)	Fluoroketone (FK- 5-1-12)	Fluoroketone (FK- 5-1-12)
Product Code	CF-001340AA	CF-001342AA	CF-001344AA	CF-001346AA	CF-001348AA
Certification type	PED, UKCA-PED, BSI Tested	PED, UKCA-PED, BSI Tested	PED, UKCA-PED, BSI Tested	PED, UKCA-PED, BSI Tested	PED, UKCA-PED, BSI Tested
PED	Yes	Yes	Yes	Yes	Yes
UKCA-PED	Yes	Yes	Yes	Yes	Yes
Gross Weight (approx.)	0.695 Kg	0.935 kg	1.07 Kg	1.27 Kg	1.46 Kg
Net Mass (approx.)	100 Gm	200 Gm	300 Gm	400 Gm	500 Gm
Total Height of Fire Ext. (approx)	148 mm	248 mm	240 mm	295 mm	350 mm
Maximum Volume Covered*	0.130 m <sup>3</sup>	0.260 m <sup>3</sup>	0.390 m <sup>3</sup>	0.520 m <sup>3</sup>	0.650 m <sup>3</sup>
Discharge Mechanism	Automatic QBD**	Automatic QBD**	Automatic QBD**	Automatic QBD**	Automatic QBD**
Can Construction	Deep Drawn & MIG Welded	Deep Drawn & MIG Welded	Deep Drawn & MIG Welded	Deep Drawn & MIG Welded	Deep Drawn & MIG Welded
Valve/Cap Construction	Machining	Machining	Machining	Machining	Machining
External Coating	Epoxy Polyester Powder	Epoxy Polyester Powder	Epoxy Polyester Powder	Epoxy Polyester Powder	Epoxy Polyester Powder
Warranty in Years	5	5	5	5	5
Min. Discharge Time	1 to 3 sec	1 to 3 sec	1 to 3 sec	1 to 3 sec	1 to 3 sec
Working Pressure	10 Bar / 12 Bar	10 Bar / 12 Bar	10 Bar / 12 Bar	10 Bar / 12 Bar	10 Bar / 12 Bar
Dia. of Shell (OD)	40 mm	40 mm	50 mm	50 mm	50 mm
Operating Temp.	-30°C to +60°C	-30°C to +60°C	-30°C to +60°C	-30°C to +60°C	-30°C to +60°C
Hydrostatic Test Pressure	35 Bar	35 Bar	35 Bar	35 Bar	35 Bar
Body Thickness	1.2 mm	1.2 mm	1.2 mm	1.2 mm	1.2 mm

\*Ideally be placed 0 to 150 mm from the ceiling of the enclosed area.

**\*\*QUARTZOID BULB KEY [QBD]**

- 57°C / 135°F
- 68°C / 155°F
- 79°C / 174°F
- 93°C / 200°F
- 141°C / 286°F
- 182°C / 360°F
- 227°C / 440°F



**TECHNICAL SPECIFICATIONS: MINI ADAPTIVE AUTOMATIC EXTINGUISHERS WITH 100mm BARREL**

Nomenclature	Mini Adaptive Automatic Fire Ext 100gm SS SP Red w/100mm barrel	Mini Adaptive Automatic Fire Ext 200gm SS SP Red w/100mm barrel	Mini Adaptive Automatic Fire Ext 300gm SS SP Red w/100mm barrel	Mini Adaptive Automatic Fire Ext 400gm SS SP Red w/100mm barrel	Mini Adaptive Automatic Fire Ext 500gm SS SP Red w/100mm barrel
Stored Pressure/Cartridge	Stored Pressure	Stored Pressure	Stored Pressure	Stored Pressure	Stored Pressure
Agent	Fluoroketone (FK- 5-1-12)	Fluoroketone (FK- 5-1-12)	Fluoroketone (FK- 5-1-12)	Fluoroketone (FK- 5-1-12)	Fluoroketone (FK- 5-1-12)
Product Code	CF-001340AB	CF-001342AB	CF-001344AB	CF-001346AB	CF-001348AB
Certification type	PED, UKCA-PED, BSI Tested	PED, UKCA-PED, BSI Tested	PED, UKCA-PED, BSI Tested	PED, UKCA-PED, BSI Tested	PED, UKCA-PED, BSI Tested
PED	Yes	Yes	Yes	Yes	Yes
UKCA-PED	Yes	Yes	Yes	Yes	Yes
Gross Weight (approx.)	0.738 Kg	0.970 Kg	1.12 Kg	1.30 Kg	1.50 Kg
Net Mass (approx.)	100 Gm	200 Gm	300 Gm	400 Gm	500 Gm
Total Height of Fire Ext. (approx)	148 mm	248 mm	240 mm	295 mm	350 mm
Maximum Volume Covered*	0.130 m <sup>3</sup>	0.260 m <sup>3</sup>	0.390 m <sup>3</sup>	0.520 m <sup>3</sup>	0.650 m <sup>3</sup>
Discharge Mechanism	Automatic QBD**	Automatic QBD**	Automatic QBD**	Automatic QBD**	Automatic QBD**
Can Construction	Deep Drawn & MIG Welded	Deep Drawn & MIG Welded	Deep Drawn & MIG Welded	Deep Drawn & MIG Welded	Deep Drawn & MIG Welded
Valve/Cap Construction	Machining	Machining	Machining	Machining	Machining
External Coating	Epoxy Polyester Powder	Epoxy Polyester Powder	Epoxy Polyester Powder	Epoxy Polyester Powder	Epoxy Polyester Powder
Warranty in Years	5	5	5	5	5
Min. Discharge Time	1 to 3 sec	1 to 3 sec	1 to 3 sec	1 to 3 sec	1 to 3 sec
Working Pressure	10 Bar / 12 Bar	10 Bar / 12 Bar	10 Bar / 12 Bar	10 Bar / 12 Bar	10 Bar / 12 Bar
Dia. of Shell (OD)	40 mm	40 mm	50 mm	50 mm	50 mm
Operating Temp.	-30°C to +60°C	-30°C to +60°C	-30°C to +60°C	-30°C to +60°C	-30°C to +60°C
Hydrostatic Test Pressure	35 Bar	35 Bar	35 Bar	35 Bar	35 Bar
Body Thickness	1.2 mm	1.2 mm	1.2 mm	1.2 mm	1.2 mm

\*Ideally be placed 0 to 150 mm from the ceiling of the enclosed area.

**\*\*QUARTZOID BULB KEY [QBD]**

- 57°C / 135°F
- 68°C / 155°F
- 79°C / 174°F
- 93°C / 200°F
- 141°C / 286°F
- 182°C / 360°F
- 227°C / 440°F

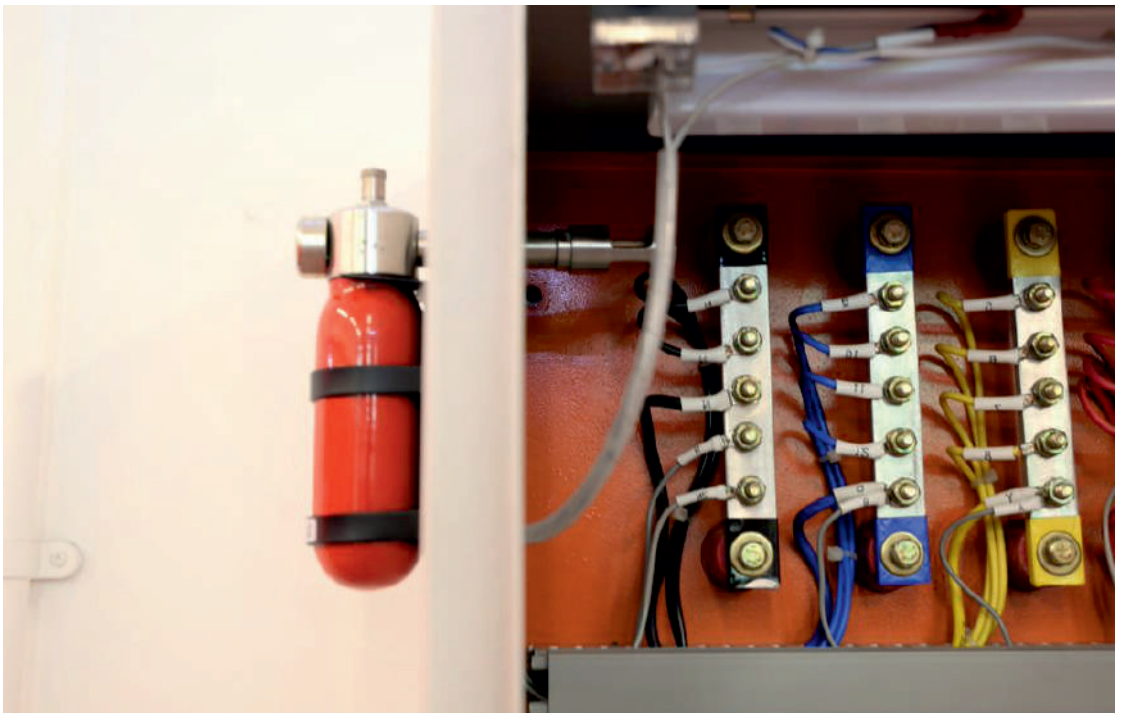

**TECHNICAL SPECIFICATIONS: MINI ADAPTIVE AUTOMATIC EXTINGUISHERS WITH 200mm BARREL**

Nomenclature	Mini Adaptive Automatic Fire Ext 100gm SS SP Red w/200mm barrel	Mini Adaptive Automatic Fire Ext 200gm SS SP Red w/200mm barrel	Mini Adaptive Automatic Fire Ext 300gm SS SP Red w/200mm barrel	Mini Adaptive Automatic Fire Ext 400gm SS SP Red w/200mm barrel	Mini Adaptive Automatic Fire Ext 500gm SS SP Red w/200mm barrel
Stored Pressure/Cartridge	Stored Pressure	Stored Pressure	Stored Pressure	Stored Pressure	Stored Pressure
Agent	Fluoroketone (FK- 5-1-12)	Fluoroketone (FK- 5-1-12)	Fluoroketone (FK- 5-1-12)	Fluoroketone (FK- 5-1-12)	Fluoroketone (FK- 5-1-12)
Product Code	CF-001340AC	CF-001342AC	CF-001344AC	CF-001346AC	CF-001348AC
Certification type	PED, UKCA-PED, BSI Tested	PED, UKCA-PED, BSI Tested	PED, UKCA-PED, BSI Tested	PED, UKCA-PED, BSI Tested	PED, UKCA-PED, BSI Tested
PED	Yes	Yes	Yes	Yes	Yes
UKCA-PED	Yes	Yes	Yes	Yes	Yes
Gross Weight (approx.)	0.822 Kg	1.05 Kg	1.20 Kg	1.39 Kg	1.58 Kg
Net Mass (approx.)	100 Gm	200 Gm	300 Gm	400 Gm	500 Gm
Total Height of Fire Ext. (approx)	148 mm	248 mm	240 mm	295 mm	350 mm
Maximum Volume Covered*	0.130 m <sup>3</sup>	0.260 m <sup>3</sup>	0.390 m <sup>3</sup>	0.520 m <sup>3</sup>	0.650 m <sup>3</sup>
Discharge Mechanism	Automatic QBD**	Automatic QBD**	Automatic QBD**	Automatic QBD**	Automatic QBD**
Can Construction	Deep Drawn & MIG Welded	Deep Drawn & MIG Welded	Deep Drawn & MIG Welded	Deep Drawn & MIG Welded	Deep Drawn & MIG Welded
Valve/Cap Construction	Machining	Machining	Machining	Machining	Machining
External Coating	Epoxy Polyester Powder	Epoxy Polyester Powder	Epoxy Polyester Powder	Epoxy Polyester Powder	Epoxy Polyester Powder
Warranty in Years	5	5	5	5	5
Min. Discharge Time	1 to 3 sec	1 to 3 sec	1 to 3 sec	1 to 3 sec	1 to 3 sec
Working Pressure	10 Bar / 12 Bar	10 Bar / 12 Bar	10 Bar / 12 Bar	10 Bar / 12 Bar	10 Bar / 12 Bar
Dia. of Shell (OD)	40 mm	40 mm	50 mm	50 mm	50 mm
Operating Temp.	-30°C to +60°C	-30°C to +60°C	-30°C to +60°C	-30°C to +60°C	-30°C to +60°C
Hydrostatic Test Pressure	35 Bar	35 Bar	35 Bar	35 Bar	35 Bar
Body Thickness	1.2 mm	1.2 mm	1.2 mm	1.2 mm	1.2 mm

\*Ideally be placed 0 to 150 mm from the ceiling of the enclosed area.

**\*\*QUARTZOID BULB KEY (QBD)**

- 57°C / 135°F
- 68°C / 155°F
- 79°C / 174°F
- 93°C / 200°F
- 141°C / 286°F
- 182°C / 360°F
- 227°C / 440°F



# Ceasefire Launcher

The Extinguisher that Doubles  
Up as Modular Suppression





# LAUNCHER (EXTINGUISHER + MODULAR SUPPRESSION SYSTEM)

## OVERVIEW:

This one-of-a-kind extinguisher can be used to fight a fire manually, on automatic suppression when it senses a rise in temperature, or be thrown into the flames. This makes it a revolutionary extinguisher that ensures no fire ever goes undetected or unaddressed. Its biggest advantage is that it eliminates the need for a firefighter to go anywhere near the fire. A huge benefit, especially in case of a large blaze.

## FEATURES:

- Fights class A, B, C and Electrically started fires.
- Unique Discharge Mechanism.
- Self-Actuation.
- Quick and effective.
- Two Heat Sensors.
- Extinguisher + Modular Suppression System.
- Equipped with Schraeder Valve and Pressure Relief Valve.



Tested by **bsi.**



## TECHNICAL SPECIFICATIONS: LAUNCHER AUTOMATIC EXTINGUISHERS

Nomenclature	Launcher Automatic Fire Ext 4KG MS SP	Launcher Automatic Fire Ext 6KG MS SP	Launcher Automatic Fire Ext 9KG MS SP
Agent	ABC Powder MAP 90	ABC Powder MAP 90	ABC Powder MAP 90
Throw (min.)	4 meters	6 meters	7 meters
Product Code	CF-000727	CF-000728	CF-000729
Certification type	PED, UKCA-PED, BSI Tested	PED, UKCA-PED, BSI Tested	PED, UKCA-PED, BSI Tested
PED	Yes	Yes	Yes
UKCA-PED	Yes	Yes	Yes
Gross Weight (approx.)	8.7 kg	11.5 kg	16.8 kg
Net Mass (approx.)	4 kg	6 kg	9 kg
Height of Fire Ext.(approx)	505 mm	545 mm	675 mm
Maximum Area Covered*	3.30 m <sup>2</sup>	5.88 m <sup>2</sup>	9.29 m <sup>2</sup>
Discharge Mechanism	Squeeze Grip / Automatic QBD***	Squeeze Grip / Automatic QBD***	Squeeze Grip / Automatic QBD***
Fire Ratings**	21A   144B	27A   183B	43A   233B
Can Construction	Deep Drawn & MIG Welded	Deep Drawn & MIG Welded	Deep Drawn & MIG Welded
Valve/Cap Construction	Forging and Machining	Forging and Machining	Forging and Machining
External Coating	Epoxy Polyester Powder	Epoxy Polyester Powder	Epoxy Polyester Powder
Warranty in Years	5	5	5
Min. Discharge Time	13 sec	15	23
Working Pressure	15 Bar	15 Bar	15 Bar
Dia. of Shell (OD)	140 mm	160 mm	175 mm
Operating Temp.	-30°C to +60°C	-30°C to +60°C	-30°C to +60°C
Hydrostatic Test Pressure	35 Bar	35 Bar	35 Bar
Body Thickness	1.6 mm	1.6 mm	2 mm
Schraeder Valve	Yes	Yes	Yes
Pressure relief valve	Yes	Yes	Yes

\*Maximum height of the extinguisher from the floor in enclosed area: 1.5 m.

\*\*Ratings are based on equivalent capacities of ABC Powder type Stored Pressure extinguishers.

### \*\*\*QUARTZOID BULB KEY (QBD)

- 57°C / 135°F
- 68°C / 155°F
- 79°C / 174°F
- 93°C / 200°F
- 141°C / 286°F
- 182°C / 360°F
- 227°C / 440°F

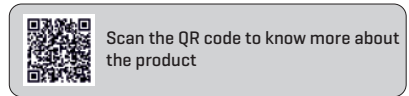



# Ceasefire Accessories

Increasing the Agility  
& Intelligence Quotient  
of Fire Extinguishers



## CEASEFIRE INSTALERT

### OVERVIEW:

Even though environments are protected with fire extinguishers, what protects the extinguishers from being misused, vandalised or stolen? What you need is a device that can protect the extinguisher 24x7. So that in the case of an emergency, the extinguisher works perfectly, puts out the flames and saves lives.

Ceasefire's Instalert is one such tamper-proof device.

### FEATURES:

- Anti-theft fire alarm.
- Highly visible, compact design that's easily mountable.
- Powerful 98dB warning alarm when activated.
- Self-contained 9V DC alkaline power source.
- Tough polycarbonate housing.

### TECHNICAL SPECIFICATIONS: INSTALERT

Nomenclature	Instalert
Housing	3mm/1/8" polycarbonate
Dimensions	136mm/5.35" (height) x 136mm/5.35" (width) x 50mm/1.97" (depth)
Power Source	9V DC alkaline
Sounder Output	95dB - low / 98dB - high (at 1 metre)
Operating Cable	3mm/1/8" galvanised steel
Standby Current	None
Alarm Current	40mA at 95dB / 150mA at 98dB



Scan the QR code to know more about the product

## STROLLEYS

### OVERVIEW:

Fires can happen anywhere and at any time. Which makes it important to install extinguishers in relevant places. But, what happens when a fire breaks out and the equipment is not easy to ferry around? Ceasefire presents the perfect accessory to mobilise your fire fighting equipment. Our range of innovative fire extinguisher strolleys are capable of carrying one or two extinguishers. Think of them as life savers on wheels.

### FEATURES:

- High quality construction for easy mobility.
- Retractable handles.
- Photo luminescent signs for visibility through smoke and darkness.
- Powder-coated, rustproof bodies.
- Available in Single Type & Double Type.



### PRODUCT DIMENSIONS: STROLLEYS

Variants Available	Dimensions
Single Extinguisher Strolley	320 x 290 x 750 mm
Double Extinguisher Strolley	620 x 520 x 1150 mm



Scan the QR code to know more about the product

## FLAT PACK TUBULAR EXTINGUISHER STANDS (CHROME & RED)

### OVERVIEW:

An aesthetically pleasing design that epitomises functionality, these Fire Extinguisher Stands in Chrome finish are an ideal choice for most spaces. The stands come with a CO<sub>2</sub> fixing bracket and a J-bracket for easy and steady installation along with a provision to attach a sign clip for extinguisher identification.

### FEATURES:

- High quality tubular frame in chrome finish.
- Tubing diameter of 25mm.
- Black plastic stand ensure stands sit firmly at their place.
- Comes in a box packaging for ease of transit and storage.
- Easy to assemble.
- Available in Single, Double, and Triple extinguisher stand variants.
- Available in Chrome & Red Finish.



### PRODUCT DIMENSIONS: TUBULAR EXTINGUISHER STANDS

Nomenclature	Dimensions & Weight
Single Extinguisher Stand (Chrome & Red)	H70 x L710 x B320 mm   weight - 2.8 kg
Double Extinguisher Stand (Chrome & Red)	H70 x L715 x B505 mm   weight - 5.14 kg
Triple Extinguisher Stand (Chrome & Red)	H70 x L715 x B650 mm   weight - 7.41 kg



Flat Pack Tubular Stand (Chrome Finish)



Scan the QR code to know more about the product

Flat Pack Tubular Stand (Red Finish)



Scan the QR code to know more about the product

**PROVISION FOR ACCESSORIES**

The stands comes with a provision to add a placard and a clip for mounting of signage. For details on the signages available please refer to the Signages section under Accessories.

**Single Fire Extinguisher Stand**

Size: L-710 x B-320 x H-70 mm

**Double Fire Extinguisher Stand**

Size: L-715 x B-505 x H-70 mm

**Triple Fire Extinguisher Stand**

Size: L-715 x B-650 x H-70 mm



## SIGNAGES

### OVERVIEW:

Did you know that the majority of the fires start in electrical mains, or because of an electrical short circuit? And even those fires that start elsewhere may, eventually result in a failure of electricity, because of damage to the mains and wiring. Which means that in a fire situation, you can be sure that at some point, the entire premises will be plunged into darkness.

Noxious black smoke will fill the air, increasing the risk of asphyxiation for all in the area. A frightening scenario when you consider the fact that asphyxiation and smoke poisoning are the highest causes of casualties in any fire. Darkness and poisonous smoke. A sure recipe for panic and utter chaos.

In such a situation, the single most important need of the hour is to evacuate all those on the premises to the nearest point of safety. As efficiently and quickly as possible. And Ceasefire, quite literally, shows you the way.



## Fire action

if you discover a fire

	<b>Operate nearest fire alarm point.</b>
	<b>Call the Fire brigade by telephoning <span style="border: 1px solid white; padding: 0 5px;">  </span> 999</b>
	<b>Leave the building by the nearest exit.</b>
	<b>Report to your assembly point at <span style="border: 1px solid white; padding: 0 5px;">  </span></b>
	<b>Do not stop to collect personal belongings.</b>
	<b>Do not use lift.</b>

### FIRE SAFETY SIGNS

Locator signs, fire extinguisher identification signs and more.





	Safe for: Wood, paper and textiles. ✓
	Not for: Flammable liquids.
	Not for: Flammable metal fires.
	Not for: Live electrical equipment.

Water





	Safe for: Wood, paper and textiles. ✓
	Safe for: Flammable liquids. ✓
	Safe for: Gaseous fires. ✓
	Safe for: Live electrical equipment. ✓

ABC Powder





	Safe for: Wood, paper and textiles. ✓
	Safe for: Flammable liquids. ✓
	Not for: Flammable metal fires.
	Not for: Live electrical equipment.

Foam





	Safe for: Wood, paper and textiles. ✓
	Not for: Flammable liquids.
	Not for: Flammable gases.
	Not for: Live electrical equipment.
	Safe for: Cooking oils and deep fat fires. ✓

Wet Chemical



In case of a fire, the firefighting equipment on the premises needs to be located and activated quickly. Ceasefire Fire Safety Signs

help guide people to the nearest extinguishers, hosepipes, emergency alarms and so on.





CODE: CF-001522  
Size: 200 X 150 MM



CODE: CF-001523  
Size: 300 X 250 MM



CODE: CF-001524  
Size: 200 X 150 MM



CODE: CF-001525  
Size: 300 X 250 MM



CODE: CF-001526  
Size: 200 X 150 MM



CODE: CF-001527  
Size: 300 X 250 MM



CODE: CF-001528  
Size: 200 X 150 MM



CODE: CF-001529  
Size: 300 X 250 MM



CODE: CF-001530  
Size: 200 X 150 MM



CODE: CF-001531  
Size: 300 X 250 MM



CODE: CF-001532  
Size: 200 X 150 MM

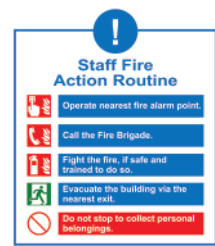

CODE: CF-001533  
Size: 300 X 250 MM



**Water**

- Safe for: Wood, paper and textiles. ✓
- Not for: Flammable liquids. ✗
- Not for: Flammable metal fires. ✗
- Not for: Live electrical equipment. ✗

CODE: CF-001513  
Size: 150 X 105 MM



**Foam**

- Safe for: Wood, paper and textiles. ✓
- Safe for: Flammable liquids. ✓
- Not for: Flammable metal fires. ✗
- Not for: Live electrical equipment. ✗

CODE: CF-001514  
Size: 150 X 105 MM



**Carbon Dioxide**

- Not for: Wood, paper and textiles. ✗
- Safe for: Flammable liquids. ✓
- Not for: Flammable metal fires. ✗
- Safe for: Live electrical equipment. ✓

CODE: CF-001515  
Size: 150 X 105 MM



**ABC Powder**

- Safe for: Wood, paper and textiles. ✓
- Safe for: Flammable liquids. ✓
- Safe for: Gaseous fires. ✓
- Safe for: Live electrical equipment. ✓

CODE: CF-001516  
Size: 150 X 105 MM



**Wet Chemical**

- Safe for: Wood, paper and textiles. ✓
- Not for: Flammable liquids. ✗
- Not for: Flammable gases. ✗
- Not for: Live electrical equipment. ✗
- Safe for: Cooking oils and deep fat fires. ✓

CODE: CF-001517  
Size: 150 X 105 MM



**Water Mist**

- Safe for: Wood, paper and textiles. ✓
- Not for: Flammable liquids. ✗
- Not for: Live electrical equipment. ✗
- Safe for: Cooking oils and deep fat fires. ✓

CODE: CF-001518  
Size: 150 X 105 MM



**Foam Mist**

- Safe for: Wood, paper and textiles. ✓
- Safe for: Flammable liquids. ✓
- Safe for: Live electrical equipment. ✓
- Safe for: Cooking oils and deep fat fires. ✓

CODE: CF-001519  
Size: 150 X 105 MM



**BC Powder**

- Not for: Wood, paper and textiles. ✗
- Safe for: Flammable liquids. ✓
- Safe for: Gaseous fires. ✓
- Safe for: Live electrical equipment. ✓

CODE: CF-001520  
Size: 150 X 105 MM



**Clean Agent**

- Not for: Wood, paper and textiles. ✗
- Safe for: Flammable liquids. ✓
- Not for: Flammable metal fires. ✗
- Safe for: Live electrical equipment. ✓

CODE: CF-001521  
Size: 150 X 105 MM



## FLAT PACK TROLLEYS

### OVERVIEW:

Ceasefire Trolleys exemplify functionality by adding manoeuvrability to the location points of the fire safety equipment. It enables easy transportation of the equipment to the fire source aiding efficient firefighting. The trolley has a provision to accommodate up to 2 fire buckets.

### FEATURES:

- Mild steel tubular body.
- Epoxy polyester powder coated internal container lining.
- Nylon wheels with rubber tread for sturdiness & smooth mobility.
- Comes in a box packaging for ease of transit and storage.



### PRODUCT DIMENSIONS: TROLLEYS

Nomenclature	Dimensions & Weight
Single Extinguisher Trolleys	H1100 x L563 x B419 mm   weight - 14.31 kg
Double Extinguisher Trolleys	H1100 x L643 x B419 mm   weight - 15.65 kg
Triple Extinguisher Trolleys	H1100 x L878 x B419 mm   weight - 18.1 kg



Scan the QR code to know more about the product



### PROVISION FOR ACCESSORIES

The trolleys are equipped with provisions to install fire buckets. The universal mounting bracket makes it easy to use for all extinguisher types, makes, and designs.



### Trolleys for Extinguisher and a Fire Bucket



### Trolleys for Double Extinguisher and a Fire Bucket



### Trolleys for Triple Extinguisher and a Two Fire Buckets



## MODULAR PLASTIC STANDS

### OVERVIEW:

Ceasefire Modular plastic stands are designed for both, functional simplicity and aesthetics. These one-size floor stands provide a secure and definitive placeholder for fire extinguishers at sites. With an easy-fix clip, these stands can be scaled up to hold single, double and triple extinguishers. Fire Extinguisher signages can be easily fixed to these stands providing a clear visual indication of the type of fire extinguisher.



<b>Variants available</b>	Single, Double, Triple
---------------------------	------------------------



## FLAT PACK FIRE EXTINGUISHER STAND

### OVERVIEW:

Ceasefire's Contractor Stand is a multi-utility fire safety station that stores fire extinguishers, safety signs, evacuation plan, medical kit and an evacuator as per the individual needs of the premises.

This being a comprehensive unit carries ample ammunition to provide first line of defence against fire. The stand comes with wheels that make it maneuverable, easy to cart around and can be taken to the point of fire with much ease.

### FEATURES:

- Stand body is built using a round tube made of mild steel.
- Outer body is epoxy polyester powder coated in red .
- The base has plastic wheels with nylon tyres that aids easy mobility.
- Comes in a box packaging for ease of transit and storage.
- The Ceasefire Contractor Stand can accommodate 3 extinguishers, safety signs, manual alarm, and a fire plan.





Scan the QR code to know more about the product

### PRODUCT DIMENSIONS: CONTRACTOR STAND

Nomenclature	Dimensions & Weight
Dimension	H1825 x L878 x B419 mm
Weight	30.16 kg



## SPECIALLY DESIGNED MOUNTING BRACKET

### OVERVIEW:

A unique feature offered by Ceasefire are specially designed Mounting Brackets to mount the extinguishers on various surfaces in different application areas. These brackets make sure that the extinguishers are not only securely mounted but also ensure no vibration hence keeping them absolutely silent onboard.

Available for	1 kg & 2 kg Extinguishers
---------------	---------------------------



# SUPPRESSION SYSTEMS

## IN THIS SECTION

### ENGINEERED SYSTEMS



In-Panel Tube Based  
Suppression System



Inert Gas Suppression  
System



Atom X - Retrofittable  
Suppression System

### STANDALONE SYSTEMS



Automatic Fire Extinguishers  
[Wall Mounted]



Automatic Fire Extinguishers  
[Ceiling Mounted]



Ceasefire Mini



Launcher [Extinguisher +  
Modular Systems]



# A FULL-SPECTRUM OF SUPPRESSION SYSTEMS

Ceasefire today offers an extensive range of fire suppression systems to suit the needs of every kind of premises. The range comprises of solutions ranging from Room Suppression Systems like Inert Gas & Co2 based Suppression System and Retrofittable Ceiling Mounted

Suppression System, to Cabinet Fire Systems like the In-panel Tube based Fire Suppression Systems and Ceasefire Mini - Micro Environment Fire Suppression to fire-proof small spaces that are vulnerable to catching fire.



## Widest Range of Fluoroketone Based (FK) Based Suppression



Ceasefire In-panel Tube Based Suppression



Ceasefire Mini



Ceasefire Atom X



Automatic Extinguishers [Wall mount & Ceiling mount]

### CERTIFICATIONS



Ceasefire's In-Panel Tube-Based Fire Suppression System

Ceasefire's Inert Gas & CO2 Based Fire Suppression System

# Ceasefire In-Panel Tube Based Suppression System (CQRS)

Fights Fire That You Can't Even See

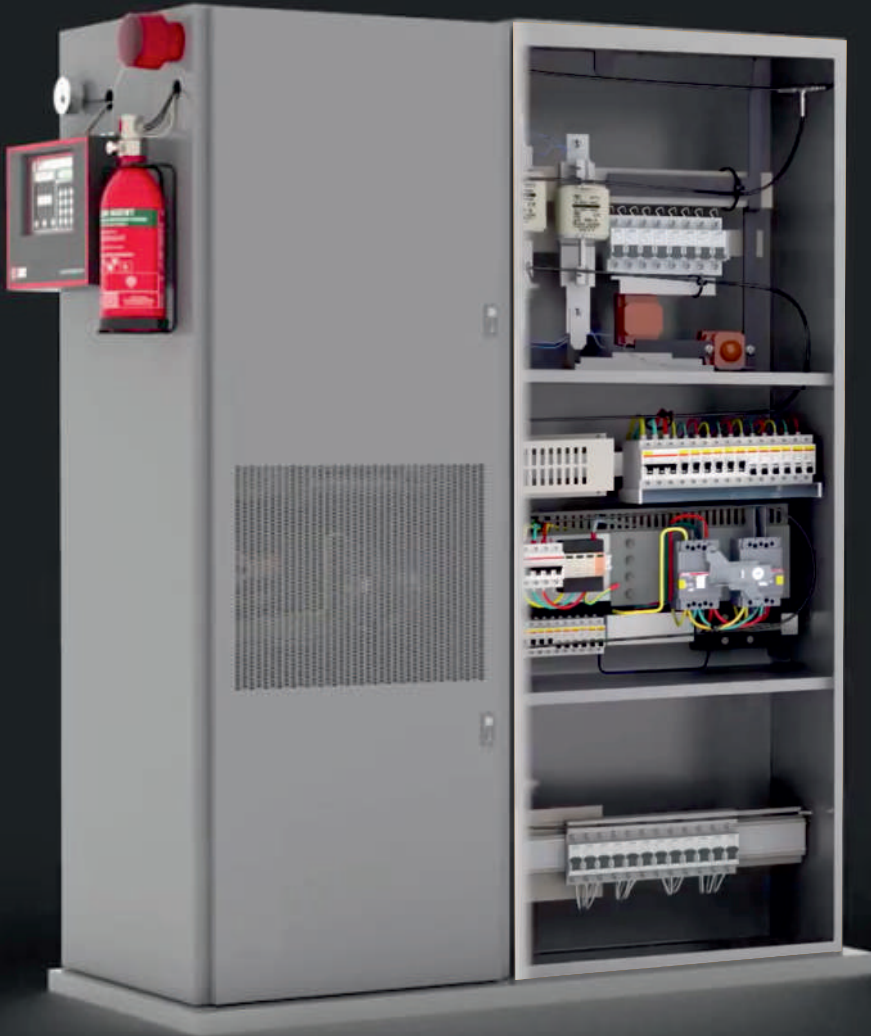

**Direct Systems**



## In-Direct Systems





# IN-PANEL TUBE BASED SUPPRESSION SYSTEM (CQRS)

## OVERVIEW:

How do you detect a fire you cannot even see? Even if detected, how do you effectively fight it in an area that is difficult to access? Ceasefire's In-Panel Tube-based Fire Suppression System (CQRS) is an advanced fire fighting solution which combines ground-breaking technology with functional simplicity to keep what's precious, safe.

## FEATURES:

- Fights Class A, B, C and Electrically started fires.
- Self-actuated.
- Environment-friendly.
- Available in two variants: High Pressure (CO<sub>2</sub> Based) & Low Pressure (Powder, Foam and Clean Agent Based) systems.
- Superior extinguishing agents - Fluoroketone (FK), MAP 90 Powder, Fluorine Free Foam & CO<sub>2</sub>.
- No clean-up required after discharge.
- 24-hour protection.
- Fluoroketone based system safe to use in confined areas.



## DIRECT VARIANT :

Agents	Sizes
Fluoroketone (Low Pressure)	2 kg, 3 kg, 4 kg, 6 kg & 9 kg
MAP 90 Powder (Low Pressure)	1 kg, 2 kg & 4 kg
Fluorine Free Foam (Low Pressure)	1 Ltr., 3 Ltr. & 6 Ltr.
CO <sub>2</sub> (High Pressure)	2 kg & 5 kg

## IN-DIRECT VARIANT :

Agents	Sizes
Fluoroketone (Low Pressure)	2 kg, 4 kg, 6 kg & 9 kg
MAP 90 Powder (Low Pressure)	2 kg, 4 kg, 6 kg & 9 kg
Fluorine Free Foam (Low Pressure)	2 Ltr., 3 Ltr., 6 Ltr. & 9 Ltr.
CO <sub>2</sub> (High Pressure)	2 kg, 5 kg & 20 kg

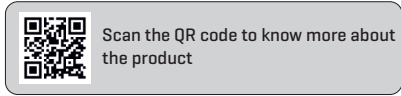

## The Complete System:

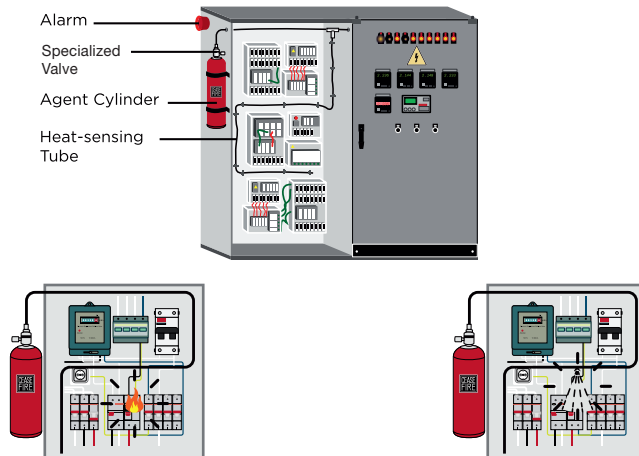

The heat-sensitive polymer tube is connected to an extinguishing agent container via a pressure release valve. When a fire breaks out, it results in a drastic increase in temperature. When it reaches 180° - 200°C, the heat-sensitive

tube bursts and activates the valve which in turn releases the extinguishing agent through the direct or indirect line. The extinguishing agent is sprayed out of the container, flooding the microenvironment and instantly extinguishing the flame.

Types of Systems:

DIRECT SYSTEM

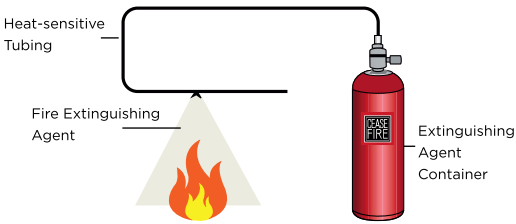

Here, the heat-sensitive tubing acts as an extinguishing agent delivery system. The tube bursts at the point where the fire is detected, forms a miniature nozzle and sprays the extinguishing agent. Ideal for places where fires can break out in localised areas. This is available in low-pressure and high-pressure systems.

INDIRECT SYSTEM

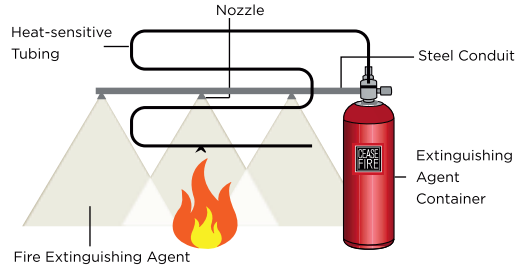

In the Indirect system, the heat-sensitive tubing only acts as a detection device. The extinguishing agent is delivered through a steel pipe and sprayed across the entire area through strategically placed nozzles. Ideal for areas where there is a chance of fires igniting at multiple points. This is available in low-pressure and high-pressure systems.



# INERT GAS SUPPRESSION SYSTEM

## OVERVIEW:

Ceasefire Inert Gas System uses inert gas or natural gases to extinguish fire. Often used as a blend of gases, these gaseous mixtures leave no residue behind and are designed to protect enclosures where there is a need for quick reaction to extinguish a fire.

Once activated, the system discharges inert gases in the fire zone, reducing the oxygen concentration below the fire threshold point. While the oxygen level is lowered, the system does not eliminate oxygen from the space altogether, leaving enough oxygen to support life but not fire!

## FEATURES:

- Fights Class A, B, C and Electrically started fires.
- Inert gas is among the most environment friendly gases.
- Safe on electronic equipments.
- Self Actuating.
- High-value Risk Protection.
- Speedy Deployment and Minimal Downtime.
- Multiple Triggers.
- 24-hour protection.



**What gases are used?**  
 CF1: CO2 [100%] | CF100: Nitrogen [100%]  
 CF541: A blend of Nitrogen[50%] + Argon[40%] + CO<sub>2</sub>[10%]  
 CF01: Argon [100%] | CF55: A mix of Argon[50%] + Nitrogen[50%]



## Components:

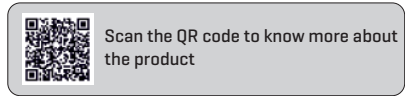

Agent Tank



Valves and Actuators



Discharge Nozzles



Pressure Gauge



Extinguishing Panel





# Atom X

Engineered Retrofittable  
Fire Suppression Systems



## ATOM X - RETROFITTABLE FIRE SUPPRESSION SYSTEM

### OVERVIEW:

Understanding the evolving demands of unique infrastructures and businesses, Ceasefire presents the next generation specialized fire suppression technology. Ceasefire Atom X doesn't demand any structural change neither consumes the floor space nor leads to down time, as this innovative system is mounted on the ceiling of the premises. Designed with smart and sensitive features, it minimizes the possibility of false activation and safeguards the premises. The system is an automated smart network of ceiling mounted agent containers, an array of detection devices and a control panel.

### FEATURES:

- Electronics and Environment-friendly.
- Dual detection & activation technology.
- Available in Fluoroketone [FK] & MAP 90 Powder.
- Self Actuating.
- Flexible Design.
- 24-hour protection.
- Fluoroketone based system safe to use in confined areas.



Tested by **bsi.**

### TECHNICAL SPECIFICATIONS: FLUOROKETONE [FK] RETROFITTABLE SUPPRESSION SYSTEM (ATOM X)

Nomenclature	Atom X - 2Kg Automatic Suppression System	Atom X - 5Kg Automatic Suppression System	Atom X - 10Kg Automatic Suppression System	Atom X - 15Kg Automatic Suppression System
Stored Pressure/Cartridge	Stored Pressure	Stored Pressure	Stored Pressure	Stored Pressure
Agent	Fluoroketone (FK- 5-1-12)	Fluoroketone (FK- 5-1-12)	Fluoroketone (FK- 5-1-12)	Fluoroketone (FK- 5-1-12)
Product Code	CF-001349A	CF-001350A	CF-001351A	CF-001352A
Certification type	PED, UKCA-PED, BSI Tested	PED, UKCA-PED, BSI Tested	PED, UKCA-PED, BSI Tested	PED, UKCA-PED, BSI Tested
PED	Yes	Yes	Yes	Yes
UKCA-PED	Yes	Yes	Yes	Yes
Gross Weight (approx.)	3.61 kg	8.8 kg	15.85 kg	20.65 kg
Net Mass (approx.)	2 kg	5 kg	10 kg	15 kg
Height of Fire Ext.(approx) with base	261 mm	333 mm	363 mm	442 mm
Maximum Volume Covered*	3 m <sup>3</sup>	7.5 m <sup>3</sup>	15 m <sup>3</sup>	22.5 m <sup>3</sup>
Actuation Mechanism	Thermal & Metron Actuator	Thermal & Metron Actuator	Thermal & Metron Actuator	Thermal & Metron Actuator
Can Construction	Deep Drawn & Mig Welded	Deep Drawn & Mig Welded	Deep Drawn & Mig Welded	Deep Drawn & Mig Welded
Valve/Cap Construction	Forging & Machining	Forging & Machining	Forging & Machining	Forging & Machining
External Coating	Epoxy Polyester Powder	Epoxy Polyester Powder	Epoxy Polyester Powder	Epoxy Polyester Powder
Warranty in Year	1	1	1	1
Min. Discharge Time	up to 6 sec	4 to 8 sec	6 to 10 sec	6 to 15
Working Pressure	10 Bar	10 Bar	10 Bar	10 Bar
Dia. of Shell (OD)	175 mm	240 mm	300 mm	300 mm
Operating Temperature	-30°C to +60°C	-30°C to +60°C	-30°C to +60°C	-30°C to +60°C
Hydrostatic Test Pressure	35 Bar	35 Bar	35 Bar	35 Bar
Body Thickness	2 mm	1.6 mm	2 mm	2 mm

\*The system container should be installed at a minimum ceiling height of 0.3 meters and a maximum ceiling height of 4.87 meters.



Scan the QR code to know more about the product



## TECHNICAL SPECIFICATIONS: MAP 90 POWDER RETROFITTABLE SUPPRESSION SYSTEM (ATOM X)

Nomenclature	Atom X - 2Kg Automatic Suppression System	Atom X - 5Kg Automatic Suppression System	Atom X - 10Kg Automatic Suppression System	Atom X - 15Kg Automatic Suppression System
Stored Pressure/Cartridge	Stored Pressure	Stored Pressure	Stored Pressure	Stored Pressure
Agent	MAP 90 Powder	MAP 90 Powder	MAP 90 Powder	MAP 90 Powder
Product Code	CF-001227A	CF-001215A	CF-001219A	CF-001231A
Certification type	PED, UKCA-PED, BSI Tested	PED, UKCA-PED, BSI Tested	PED, UKCA-PED, BSI Tested	PED, UKCA-PED, BSI Tested
PED	Yes	Yes	Yes	Yes
UKCA-PED	Yes	Yes	Yes	Yes
Gross Weight (approx.)	3.61 kg	8.8 kg	15.9 kg	20.62 kg
Net Mass (approx.)	2 kg	5 kg	10 kg	15 kg
Height of Fire Ext.(approx) with base	261 mm	333 mm	363 mm	442 mm
Maximum Area Covered*	3.14 m <sup>2</sup>	12.56 m <sup>2</sup>	28.26 m <sup>2</sup>	50.24 m <sup>2</sup>
Actuation Mechanism	Thermal & Metron Actuator	Thermal & Metron Actuator	Thermal & Metron Actuator	Thermal & Metron Actuator
Can Construction	Deep Drawn & Mig Welded	Deep Drawn & Mig Welded	Deep Drawn & Mig Welded	Deep Drawn & Mig Welded
Valve/Cap Construction	Forging & Machining	Forging & Machining	Forging & Machining	Forging & Machining
External Coating	Epoxy Polyester Powder	Epoxy Polyester Powder	Epoxy Polyester Powder	Epoxy Polyester Powder
Warranty in Year	1	1	1	1
Min. Discharge Time	up to 6 sec	4 to 8 sec	6 to 10 sec	6 to 15
Working Pressure	15 Bar	15 Bar	15 Bar	15 Bar
Dia. of Shell (OD)	175 mm	240 mm	300 mm	300 mm
Operating Temperature	-30°C to +60°C	-30°C to +60°C	-30°C to +60°C	-30°C to +60°C
Hydrostatic Test Pressure	35 Bar	35 Bar	35 Bar	35 Bar
Body Thickness	2 mm	1.6 mm	2 mm	2 mm

\*Maximum room height for 2 kg - 1.8 m, 5 kg - 3.6 m, 10 kg - 4.4 m, 15 kg - 6.5 m.





# Standalone Fire Suppression Systems

A Fusion of Cutting-Edge Technology  
and Functional Simplicity.



# AUTOMATIC FIRE EXTINGUISHERS (WALL MOUNTED)

## OVERVIEW:

Ceasefire's Inverted Automatic Fire Extinguisher addresses two simple problems; first of fire safety and second of space crunch. Being an automatic extinguisher it is ideal for spaces like boats and engine compartments that are not just prone to fire but also have limited space, where installing an extinguisher can be a challenge.

## FEATURES:

- Comes in option of Fluoroketone and Powder.
- Clean agent Fluoroketone extinguishers do not fall under the F-gas regulations.
- Works on all classes of fire.
- Automatic detection and suppression.
- Comes with a secure mounting bracket for direct installation on the wall.
- Optional flexible mounting bracket that enables optimal positioning of the extinguisher in the risk zone.
- Fluoroketone extinguishers safe to use in confined areas.



## TECHNICAL SPECIFICATIONS: FLUOROKETONE (FK) AUTOMATIC EXTINGUISHERS

Nomenclature	Automatic Fire Ext 1Kg MS SP Red	Automatic Fire Ext 1.5Kg MS SP Red	Automatic Fire Ext 2Kg MS SP Red	Automatic Fire Ext 2.5Kg MS SP Red	Automatic Fire Ext 4Kg MS SP Red	Automatic Fire Ext 6Kg MS SP Red	Automatic Fire Ext 9Kg MS SP Red
Agent	Fluoroketone (FK-5-1-12)	Fluoroketone (FK-5-1-12)	Fluoroketone (FK-5-1-12)	Fluoroketone (FK-5-1-12)	Fluoroketone (FK-5-1-12)	Fluoroketone (FK-5-1-12)	Fluoroketone (FK-5-1-12)
Product Code	CF-001411	CF-001412	CF-001413	CF-001414	CF-001415	CF-001416	CF-001417
Certification type	PED, UKCA-PED	PED, UKCA-PED	PED, UKCA-PED	PED, UKCA-PED	PED, UKCA-PED	PED, UKCA-PED	PED, UKCA-PED
PED	Yes	Yes	Yes	Yes	Yes	Yes	Yes
UKCA-PED	Yes	Yes	Yes	Yes	Yes	Yes	Yes
Gross Weight (approx.)	1.8 kg	2.8 kg	3.3 kg	4.1 kg	6 kg	8.7 kg	12.9 kg
Net Mass (approx.)	1 kg	1.5 kg	2 kg	2.5 kg	4 kg	6 kg	9 kg
Maximum Volume Covered*	1.4 m <sup>3</sup>	2.1 m <sup>3</sup>	2.8 m <sup>3</sup>	3.5 m <sup>3</sup>	5.7 m <sup>3</sup>	8.5 m <sup>3</sup>	12.8 m <sup>3</sup>
Height of Fire Ext.(approx)	330 mm	350 mm	350 mm	290 mm	396 mm	446 mm	577 mm
Discharge Mechanism	Automatic QBD**	Automatic QBD**	Automatic QBD**	Automatic QBD**	Automatic QBD**	Automatic QBD**	Automatic QBD**
Can Construction	Deep Drawn & MIG Welded	Deep Drawn & MIG Welded	Deep Drawn & MIG Welded	Deep Drawn & MIG Welded	Deep Drawn & MIG Welded	Deep Drawn & MIG Welded	Deep Drawn & MIG Welded
Valve/Cap Construction	Forging & Machining	Forging & Machining	Forging & Machining	Forging & Machining	Forging & Machining	Forging & Machining	Forging & Machining
External Coating	Epoxy Polyester Powder	Epoxy Polyester Powder	Epoxy Polyester Powder	Epoxy Polyester Powder	Epoxy Polyester Powder	Epoxy Polyester Powder	Epoxy Polyester Powder
Warranty in Years	5	5	5	5	5	5	5
Min. Discharge Time	0.5 sec	0.6 sec	1 sec	1 sec	2 sec	3 sec	4 sec
Working Pressure	10 Bar	10 Bar	10 Bar	10 Bar	10 Bar	10 Bar	10 Bar
Dia. of Shell (OD)	86.5 mm	108 mm	108 mm	140 mm	140 mm	160 mm	175 mm
Operating Temp.	-30°C to +60°C	-30°C to +60°C	-30°C to +60°C	-30°C to +60°C	-30°C to +60°C	-30°C to +60°C	-30°C to +60°C
Hydrostatic Test Pressure	30 Bar	30 Bar	30 Bar	30 Bar	30 Bar	30 Bar	30 Bar
Body Thickness	1.6 mm	1.6 mm	1.6 mm	1.6 mm	1.6 mm	1.6 mm	2 mm

\*Maximum height of the extinguisher from the floor: 3.6 m.

## \*\*QUARTZOID BULB KEY (QBD)

- 57°C / 135°F
- 68°C / 155°F
- 79°C / 174°F
- 93°C / 200°F
- 141°C / 286°F
- 182°C / 360°F
- 227°C / 440°F

## Fluoroketone Extinguishers (FK-5-1-12)

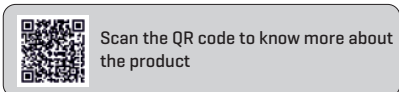

## TECHNICAL SPECIFICATIONS: ABC POWDER MAP 50 AUTOMATIC EXTINGUISHERS

Nomenclature	Automatic Fire Ext 1Kg MS SP Red	Automatic Fire Ext 2Kg MS SP Red	Automatic Fire Ext 4Kg MS SP Red	Automatic Fire Ext 6Kg MS SP Red	Automatic Fire Ext 9Kg MS SP Red
Agent	ABC Powder MAP 50	ABC Powder MAP 50	ABC Powder MAP 50	ABC Powder MAP 50	ABC Powder MAP 50
Product Code	CF-001401	CF-001402	CF-001403	CF-001404	CF-001405
Certification type	PED, UKCA-PED	PED, UKCA-PED	PED, UKCA-PED	PED, UKCA-PED	PED, UKCA-PED
PED	Yes	Yes	Yes	Yes	Yes
UKCA-PED	Yes	Yes	Yes	Yes	Yes
Gross Weight (approx.)	1.8 kg	3.3 kg	6 kg	8.7 kg	12.9 kg
Net Mass (approx.)	1 kg	2 kg	4 kg	6 kg	9 kg
Height of Fire Ext.(approx)	330 mm	350 mm	396 mm	446 mm	577 mm
Maximum Area Covered*	1.6 m <sup>2</sup>	2.3 m <sup>2</sup>	6.3 m <sup>2</sup>	9.8 m <sup>2</sup>	19.2 m <sup>2</sup>
Discharge Mechanism	Automatic QBD**	Automatic QBD**	Automatic QBD**	Automatic QBD**	Automatic QBD**
Can Construction	Deep Drawn & MIG Welded	Deep Drawn & MIG Welded	Deep Drawn & MIG Welded	Deep Drawn & MIG Welded	Deep Drawn & MIG Welded
Valve/Cap Construction	Forging & Machining	Forging & Machining	Forging & Machining </tr		

\*Maximum room height for 1 kg - 1.5 m, 2 kg - 2 m, 4 kg - 3.2 m, 6 kg - 3.2 m, 9 kg - 3.2 m.

## \*\*QUARTZOID BULB KEY (QBD)

● 57°C / 135°F ● 68°C / 155°F ● 79°C / 174°F ● 93°C / 200°F ● 141°C / 286°F ● 182°C / 360°F ● 227°C / 440°F

## TELESCOPING WALL MOUNTING BRACKET

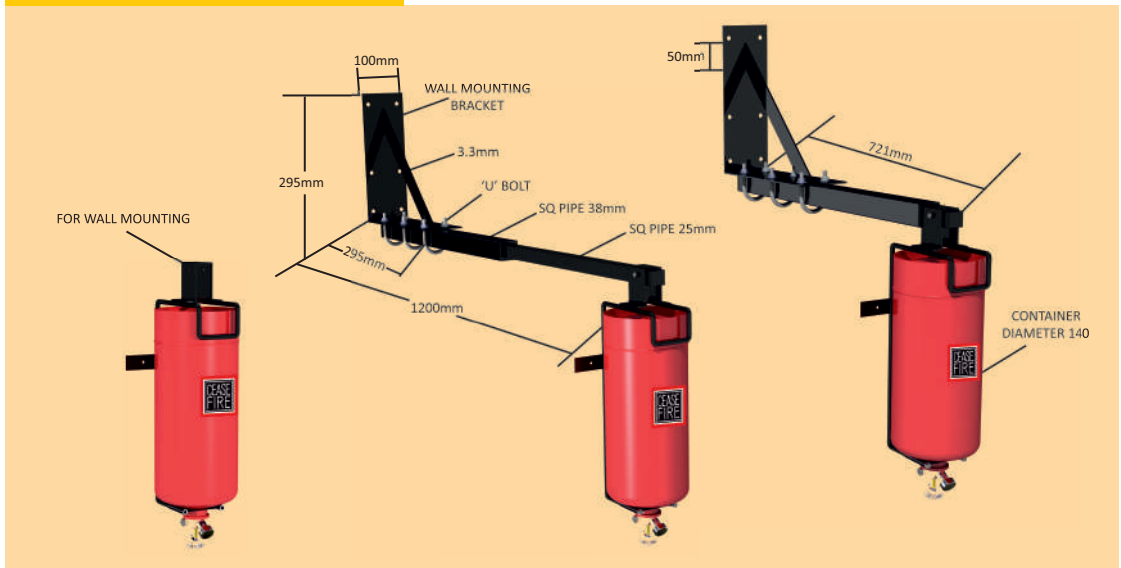

## ABC Powder Extinguishers (MAP 90)



Scan the QR code to know more about the product



## AUTOMATIC FIRE EXTINGUISHERS (CEILING MOUNTED)

### OVERVIEW:

There are areas in a workplace that contain highly flammable materials with little or no human traffic. Here, the chances of fire going undetected are high. Ceasefire's Ceiling mounted extinguisher detects the rising temperature of the area and activates automatically, even when there's no one around, ensuring that the fire is brought under control early and efficiently.

### FEATURES:

- Fights class A, B, C and Electrically started fires.
- Automatic discharge mechanism.
- Rigid ceiling mount.
- Comes in option of Fluoroketone and Powder.
- Green Technology.
- Fluoroketone extinguishers safe to use in confined areas.



Tested by **bsi.**

FIGHTS CLASS CERTIFICATIONS

A B C ⚡ CE<sub>1128</sub> UKCA

### TECHNICAL SPECIFICATIONS: CEILING MOUNTED AUTOMATIC EXTINGUISHERS

Nomenclature	Ceiling Mounted 5Kg MS SP Red	Ceiling Mounted 10Kg MS SP Red	Ceiling Mounted 5Kg MS SP Red	Ceiling Mounted 10Kg MS SP Red
Stored Pressure/Cartridge	Stored Pressure	Stored Pressure	Stored Pressure	Stored Pressure
Agent	MAP 90	MAP 90	Fluoroketone (FK- 5-1-12)	Fluoroketone (FK- 5-1-12)
Product Code	CF-000017	CF-000018	CF-001337	CF-001338
Certification type	PED, UKCA-PED, BSI Tested	PED, UKCA-PED, BSI Tested	PED, UKCA-PED, BSI Tested	PED, UKCA-PED, BSI Tested
PED	Yes	Yes	Yes	Yes
UKCA-PED	Yes	Yes	Yes	Yes
Gross Weight (approx.)	7.8 kg	14.9 kg	7.8 kg	14.9 kg
Net Mass (approx.)	5 kg	10 kg	5 kg	10 kg
Height of Fire Ext.(approx) with base	332.5 mm	362.5 mm	332.5 mm	362.5 mm
Maximum Area*/Volume Covered	upto 12 m <sup>2</sup>	upto 28 m <sup>2</sup>	7 m <sup>3</sup>	15 m <sup>3</sup>
Discharge Mechanism	Automatic QBD**	Automatic QBD**	Automatic QBD**	Automatic QBD**
Can Construction	Deep Drawn & MIG Welded	Deep Drawn & MIG Welded	Deep Drawn & MIG Welded	Deep Drawn & MIG Welded
Valve/Cap Construction	Forging & Machining	Forging & Machining	Forging & Machining	Forging & Machining
External Coating	Epoxy Polyester Powder	Epoxy Polyester Powder	Epoxy Polyester Powder	Epoxy Polyester Powder
Warranty in Years	5	5	5	5
Min. Discharge Time	4 to 8 sec	6 to 10 sec	4 to 8 sec	6 to 10 sec
Working Pressure	15 Bar	15 Bar	10 Bar	10 Bar
Dia. of Shell (OD)	240 mm	300 mm	240 mm	300 mm
Operating Temp.	-30°C to +60°C	-30°C to +60°C	-30°C to +60°C	-30°C to +60°C
Hydrostatic Test Pressure	35 Bar	35 Bar	35 Bar	35 Bar
Body Thickness	1.6 mm	2 mm	1.6 mm	2 mm

\*Maximum ceiling height 5kg - 3.6 m, 10kg - 4.4 m.

### \*\*QUARTZOID BULB KEY (QBD)

● 57°C / 135°F ● 68°C / 155°F ● 79°C / 174°F ● 93°C / 200°F ● 141°C / 286°F ● 182°C / 360°F ● 227°C / 440°F

### ABC Powder Extinguishers (MAP 90)

### Fluoroketone Extinguishers (FK-5-1-12)



Scan the QR code to know more about the product



Scan the QR code to know more about the product



# Ceasefire Mini

Designed to Protect the Most Complex Micro Spaces.



Adaptive Design



Intuitive Design



## CEASEFIRE MINI

### OVERVIEW:

The Mini is Ceasefire's state-of-the-art micro-environment suppression system. Palm-sized, it sits snugly inside small enclosed spaces that are vulnerable to fire. When the temperature of the micro-environment exceeds a preset limit, the Mini swings into action and extinguishes the fire. Servers, fuse boxes; the Mini fits anywhere, and protects everywhere.

### FEATURES:

- Fights all classes of fire.
- Self-activated and easy to install.
- Clean agent Fluoroketone based extinguishers do not fall under the F-gas regulations.
- No power supply required.
- Heat-sensitive glass bulb acts as a heat sensor and actuator.
- Mini is based on an environment friendly extinguishing agent Fluoroketone.
- Safe to use in confined areas.



FIGHTS CLASS

A B C ⚡

CERTIFICATIONS

CE UK  
CA

### Types of Mini:

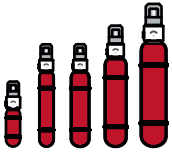

#### Intuitive System

The Mini Intuitive System is a direct suppression system, which protects the micro-environment from enclosed area inside. Place it inside, or attach it to the inner wall of the micro-environment, and the Mini is ready to protect.

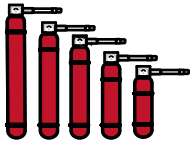
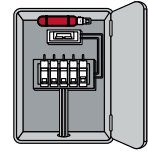

#### Adaptive System

The Mini Adaptive System is an indirect suppression system designed for those micro-environments which are too small to even accommodate a Mini, let alone other firefighting systems. In this case, the Mini container is installed on the outside, with its heat-sensitive glass bulb inside the micro-environment.

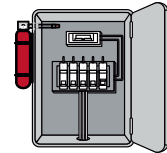

Tested by **bsi.**



Scan the QR code to know more about the product



## TECHNICAL SPECIFICATIONS: MINI INTUITIVE AUTOMATIC EXTINGUISHERS

Nomenclature	Mini Intuitive Automatic Fire Ext 100gm SS SP Red	Mini Intuitive Automatic Fire Ext 200gm SS SP Red	Mini Intuitive Automatic Fire Ext 300gm SS SP Red	Mini Intuitive Automatic Fire Ext 400gm SS SP Red	Mini Intuitive Automatic Fire Ext 500gm SS SP Red
Stored Pressure/Cartridge	Stored Pressure	Stored Pressure	Stored Pressure	Stored Pressure	Stored Pressure
Agent	Fluoroketone (FK- 5-1-12)	Fluoroketone (FK- 5-1-12)	Fluoroketone (FK- 5-1-12)	Fluoroketone (FK- 5-1-12)	Fluoroketone (FK- 5-1-12)
Product Code	CF-001339A	CF-001341A	CF-001343A	CF-001345A	CF-001347A
Certification type	PED, UKCA-PED, BSI Tested	PED, UKCA-PED, BSI Tested	PED, UKCA-PED, BSI Tested	PED, UKCA-PED, BSI Tested	PED, UKCA-PED, BSI Tested
PED	Yes	Yes	Yes	Yes	Yes
UKCA-PED	Yes	Yes	Yes	Yes	Yes
Gross Weight (approx.)	0.665 Kg	0.90 kg	1.10 Kg	1.25 Kg	1.45 Kg
Net Mass (approx.)	100 Gm	200 Gm	300 Gm	400 Gm	500 Gm
Total Height of Fire Ext. (approx.)	184 mm	284 mm	276 mm	331 mm	386 mm
Maximum Volume Covered*	0.130 m <sup>3</sup>	0.260 m <sup>3</sup>	0.290 m <sup>3</sup>	0.520 m <sup>3</sup>	0.650 m <sup>3</sup>
Discharge Mechanism	Automatic QBD**	Automatic QBD**	Automatic QBD**	Automatic QBD**	Automatic QBD**
Can Construction	Deep Drawn & MIG Welded	Deep Drawn & MIG Welded	Deep Drawn & MIG Welded	Deep Drawn & MIG Welded	Deep Drawn & MIG Welded
Valve/Cap Construction	Machining	Machining	Machining	Machining	Machining
External Coating	Epoxy Polyester Powder	Epoxy Polyester Powder	Epoxy Polyester Powder	Epoxy Polyester Powder	Epoxy Polyester Powder
Warranty in Years	5	5	5	5	5
Min. Discharge Time	1 to 3 sec	1 to 3 sec	1 to 3 sec	1 to 3 sec	1 to 3 sec
Working Pressure	10 Bar / 12 Bar	10 Bar / 12 Bar	10 Bar / 12 Bar	10 Bar / 12 Bar	10 Bar / 12 Bar
Dia. of Shell (OD)	40 mm	40 mm	50 mm	50 mm	50 mm
Operating Temp.	-30°C to +60°C	-30°C to +60°C	-30°C to +60°C	-30°C to +60°C	-30°C to +60°C
Hydrostatic Test Pressure	35 Bar	35 Bar	35 Bar	35 Bar	35 Bar
Body Thickness	1.2 mm	1.2 mm	1.2 mm	1.2 mm	1.2 mm

\* Ideally be placed 0 to 150 mm from the ceiling of the enclosed area.

## \*\*QUARTZOID BULB KEY (QBD)

● 57°C / 135°F

● 68°C / 155°F

● 79°C / 174°F

● 93°C / 200°F

● 141°C / 286°F

● 182°C / 360°F

● 227°C / 440°F



## TECHNICAL SPECIFICATIONS: MINI ADAPTIVE AUTOMATIC EXTINGUISHERS WITH 50mm BARREL

Nomenclature	Mini Adaptive Automatic Fire Ext 100gm SS SP Red w/50mm barrel	Mini Adaptive Automatic Fire Ext 200gm SS SP Red w/50mm barrel	Mini Adaptive Automatic Fire Ext 300gm SS SP Red w/50mm barrel	Mini Adaptive Automatic Fire Ext 400gm SS SP Red w/50mm barrel	Mini Adaptive Automatic Fire Ext 500gm SS SP Red w/50mm barrel
Stored Pressure/Cartridge	Stored Pressure	Stored Pressure	Stored Pressure	Stored Pressure	Stored Pressure
Agent	Fluoroketone (FK- 5-1-12)	Fluoroketone (FK- 5-1-12)	Fluoroketone (FK- 5-1-12)	Fluoroketone (FK- 5-1-12)	Fluoroketone (FK- 5-1-12)
Product Code	CF-001340AA	CF-001342AA	CF-001344AA	CF-001346AA	CF-001348AA
Certification type	PED, UKCA-PED, BSI Tested	PED, UKCA-PED, BSI Tested	PED, UKCA-PED, BSI Tested	PED, UKCA-PED, BSI Tested	PED, UKCA-PED, BSI Tested
PED	Yes	Yes	Yes	Yes	Yes
UKCA-PED	Yes	Yes	Yes	Yes	Yes
Gross Weight (approx.)	0.695 Kg	0.935 kg	1.07 Kg	1.27 Kg	1.46 Kg
Net Mass (approx.)	100 Gm	200 Gm	300 Gm	400 Gm	500 Gm
Total Height of Fire Ext. (approx)	148 mm	248 mm	240 mm	295 mm	350 mm
Maximum Volume Covered*	0.130 m <sup>3</sup>	0.260 m <sup>3</sup>	0.390 m <sup>3</sup>	0.520 m <sup>3</sup>	0.650 m <sup>3</sup>
Discharge Mechanism	Automatic QBD**	Automatic QBD**	Automatic QBD**	Automatic QBD**	Automatic QBD**
Can Construction	Deep Drawn & MIG Welded	Deep Drawn & MIG Welded	Deep Drawn & MIG Welded	Deep Drawn & MIG Welded	Deep Drawn & MIG Welded
Valve/Cap Construction	Machining	Machining	Machining	Machining	Machining
External Coating	Epoxy Polyester Powder	Epoxy Polyester Powder	Epoxy Polyester Powder	Epoxy Polyester Powder	Epoxy Polyester Powder
Warranty in Years	5	5	5	5	5
Min. Discharge Time	1 to 3 sec	1 to 3 sec	1 to 3 sec	1 to 3 sec	1 to 3 sec
Working Pressure	10 Bar / 12 Bar	10 Bar / 12 Bar	10 Bar / 12 Bar	10 Bar / 12 Bar	10 Bar / 12 Bar
Dia. of Shell (OD)	40 mm	40 mm	50 mm	50 mm	50 mm
Operating Temp.	-30°C to +60°C	-30°C to +60°C	-30°C to +60°C	-30°C to +60°C	-30°C to +60°C
Hydrostatic Test Pressure	35 Bar	35 Bar	35 Bar	35 Bar	35 Bar
Body Thickness	1.2 mm	1.2 mm	1.2 mm	1.2 mm	1.2 mm

\*Ideally be placed 0 to 150 mm from the ceiling of the enclosed area.

**\*\*QUARTZOID BULB KEY [QBD]**

● 57°C / 135°F

● 68°C / 155°F

● 79°C / 174°F

● 93°C / 200°F

● 141°C / 286°F

● 182°C / 360°F

● 227°C / 440°F





## TECHNICAL SPECIFICATIONS: MINI ADAPTIVE AUTOMATIC EXTINGUISHERS WITH 100mm BARREL

Nomenclature	Mini Adaptive Automatic Fire Ext 100gm SS SP Red w/100mm barrel	Mini Adaptive Automatic Fire Ext 200gm SS SP Red w/100mm barrel	Mini Adaptive Automatic Fire Ext 300gm SS SP Red w/100mm barrel	Mini Adaptive Automatic Fire Ext 400gm SS SP Red w/100mm barrel	Mini Adaptive Automatic Fire Ext 500gm SS SP Red w/100mm barrel
Stored Pressure/Cartridge	Stored Pressure	Stored Pressure	Stored Pressure	Stored Pressure	Stored Pressure
Agent	Fluoroketone (FK- 5-1-12)	Fluoroketone (FK- 5-1-12)	Fluoroketone (FK- 5-1-12)	Fluoroketone (FK- 5-1-12)	Fluoroketone (FK- 5-1-12)
Product Code	CF-001340AB	CF-001342AB	CF-001344AB	CF-001346AB	CF-001348AB
Certification type	PED, UKCA-PED, BSI Tested	PED, UKCA-PED, BSI Tested	PED, UKCA-PED, BSI Tested	PED, UKCA-PED, BSI Tested	PED, UKCA-PED, BSI Tested
PED	Yes	Yes	Yes	Yes	Yes
UKCA-PED	Yes	Yes	Yes	Yes	Yes
Gross Weight (approx.)	0.738 Kg	0.970 Kg	1.12 Kg	1.30 Kg	1.50 Kg
Net Mass (approx.)	100 Gm	200 Gm	300 Gm	400 Gm	500 Gm
Total Height of Fire Ext. (approx)	148 mm	248 mm	240 mm	295 mm	350 mm
Maximum Volume Covered*	0.130 m <sup>3</sup>	0.260 m <sup>3</sup>	0.390 m <sup>3</sup>	0.520 m <sup>3</sup>	0.650 m <sup>3</sup>
Discharge Mechanism	Automatic QBD**	Automatic QBD**	Automatic QBD**	Automatic QBD**	Automatic QBD**
Can Construction	Deep Drawn & MIG Welded	Deep Drawn & MIG Welded	Deep Drawn & MIG Welded	Deep Drawn & MIG Welded	Deep Drawn & MIG Welded
Valve/Cap Construction	Machining	Machining	Machining	Machining	Machining
External Coating	Epoxy Polyester Powder	Epoxy Polyester Powder	Epoxy Polyester Powder	Epoxy Polyester Powder	Epoxy Polyester Powder
Warranty in Years	5	5	5	5	5
Min. Discharge Time	1 to 3 sec	1 to 3 sec	1 to 3 sec	1 to 3 sec	1 to 3 sec
Working Pressure	10 Bar / 12 Bar	10 Bar / 12 Bar	10 Bar / 12 Bar	10 Bar / 12 Bar	10 Bar / 12 Bar
Dia. of Shell (OD)	40 mm	40 mm	50 mm	50 mm	50 mm
Operating Temp.	-30°C to +60°C	-30°C to +60°C	-30°C to +60°C	-30°C to +60°C	-30°C to +60°C
Hydrostatic Test Pressure	35 Bar	35 Bar	35 Bar	35 Bar	35 Bar
Body Thickness	1.2 mm	1.2 mm	1.2 mm	1.2 mm	1.2 mm

\*Ideally be placed 0 to 150 mm from the ceiling of the enclosed area.

## \*\*QUARTZOID BULB KEY [QBD]

● 57°C / 135°F

● 68°C / 155°F

● 79°C / 174°F

● 93°C / 200°F

● 141°C / 286°F

● 182°C / 360°F

● 227°C / 440°F

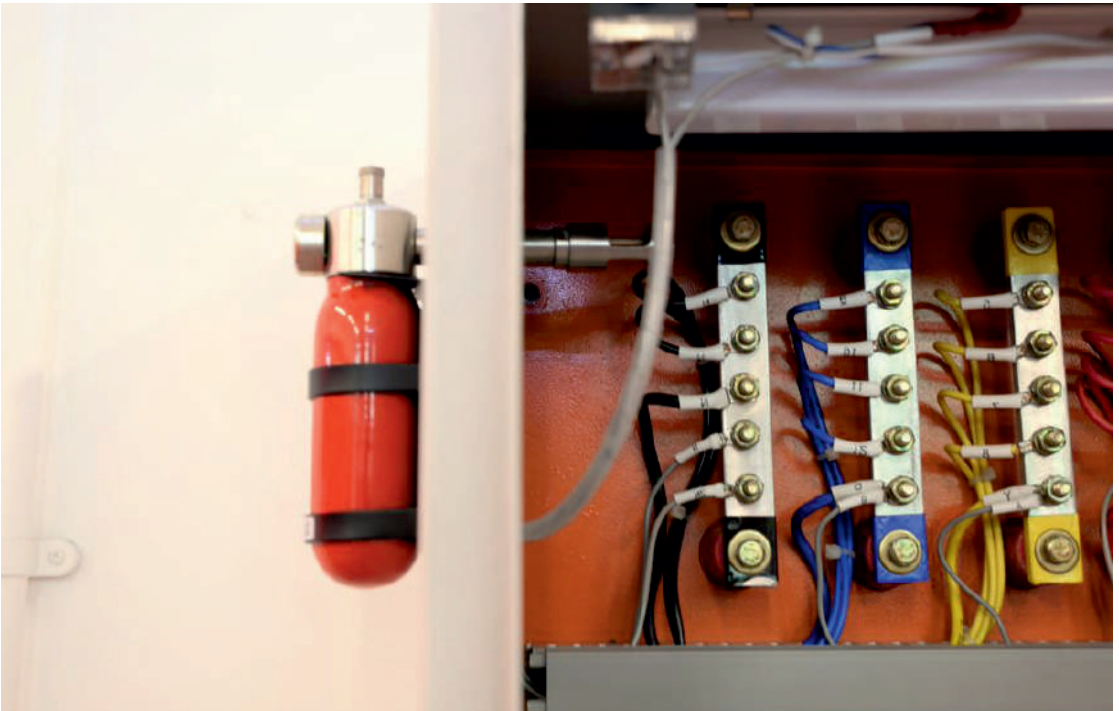



## TECHNICAL SPECIFICATIONS: MINI ADAPTIVE AUTOMATIC EXTINGUISHERS WITH 200mm BARREL

Nomenclature	Mini Adaptive Automatic Fire Ext 100gm SS SP Red w/200mm barrel	Mini Adaptive Automatic Fire Ext 200gm SS SP Red w/200mm barrel	Mini Adaptive Automatic Fire Ext 300gm SS SP Red w/200mm barrel	Mini Adaptive Automatic Fire Ext 400gm SS SP Red w/200mm barrel	Mini Adaptive Automatic Fire Ext 500gm SS SP Red w/200mm barrel
Stored Pressure/Cartridge	Stored Pressure	Stored Pressure	Stored Pressure	Stored Pressure	Stored Pressure
Agent	Fluoroketone (FK- 5-1-12)	Fluoroketone (FK- 5-1-12)	Fluoroketone (FK- 5-1-12)	Fluoroketone (FK- 5-1-12)	Fluoroketone (FK- 5-1-12)
Product Code	CF-001340AC	CF-001342AC	CF-001344AC	CF-001346AC	CF-001348AC
Certification type	PED, UKCA-PED, BSI Tested	PED, UKCA-PED, BSI Tested	PED, UKCA-PED, BSI Tested	PED, UKCA-PED, BSI Tested	PED, UKCA-PED, BSI Tested
PED	Yes	Yes	Yes	Yes	Yes
UKCA-PED	Yes	Yes	Yes	Yes	Yes
Gross Weight (approx.)	0.822 Kg	1.05 Kg	1.20 Kg	1.39 Kg	1.58 Kg
Net Mass (approx.)	100 Gm	200 Gm	300 Gm	400 Gm	500 Gm
Total Height of Fire Ext. (approx)	148 mm	248 mm	240 mm	295 mm	350 mm
Maximum Volume Covered*	0.130 m <sup>3</sup>	0.260 m <sup>3</sup>	0.390 m <sup>3</sup>	0.520 m <sup>3</sup>	0.650 m <sup>3</sup>
Discharge Mechanism	Automatic QBD**	Automatic QBD**	Automatic QBD**	Automatic QBD**	Automatic QBD**
Can Construction	Deep Drawn & MIG Welded	Deep Drawn & MIG Welded	Deep Drawn & MIG Welded	Deep Drawn & MIG Welded	Deep Drawn & MIG Welded
Valve/Cap Construction	Machining	Machining	Machining	Machining	Machining
External Coating	Epoxy Polyester Powder	Epoxy Polyester Powder	Epoxy Polyester Powder	Epoxy Polyester Powder	Epoxy Polyester Powder
Warranty in Years	5	5	5	5	5
Min. Discharge Time	1 to 3 sec	1 to 3 sec	1 to 3 sec	1 to 3 sec	1 to 3 sec
Working Pressure	10 Bar / 12 Bar	10 Bar / 12 Bar	10 Bar / 12 Bar	10 Bar / 12 Bar	10 Bar / 12 Bar
Dia. of Shell (OD)	40 mm	40 mm	50 mm	50 mm	50 mm
Operating Temp.	-30°C to +60°C	-30°C to +60°C	-30°C to +60°C	-30°C to +60°C	-30°C to +60°C
Hydrostatic Test Pressure	35 Bar	35 Bar	35 Bar	35 Bar	35 Bar
Body Thickness	1.2 mm	1.2 mm	1.2 mm	1.2 mm	1.2 mm

\*Ideally be placed 0 to 150 mm from the ceiling of the enclosed area.

## \*\*QUARTZOID BULB KEY (QBD)

● 57°C / 135°F   ● 68°C / 155°F   ● 79°C / 174°F   ● 93°C / 200°F   ● 141°C / 286°F   ● 182°C / 360°F   ● 227°C / 440°F





# Ceasefire Launcher

The Extinguisher that Doubles  
Up as Modular Suppression



POWDER

POWDER

## LAUNCHER (EXTINGUISHER + MODULAR SUPPRESSION SYSTEM)

### OVERVIEW:

This one-of-a-kind extinguisher can be used to fight a fire manually, on automatic suppression when it senses a rise in temperature, or be thrown into the flames. This makes it a revolutionary extinguisher that ensures no fire ever goes undetected or unaddressed. Its biggest advantage is that it eliminates the need for a firefighter to go anywhere near the fire. A huge benefit, especially in case of a large blaze.

### FEATURES:

- Fights class A, B, C and Electrically started fires.
- Unique Discharge Mechanism.
- Self-Actuation.
- Quick and effective.
- Two Heat Sensors.
- Extinguisher + Modular Suppression System.
- Equipped with Schraeder Valve and Pressure Relief Valve.



Tested by **bsi.**



### TECHNICAL SPECIFICATIONS: LAUNCHER AUTOMATIC EXTINGUISHERS

Nomenclature	Launcher Automatic Fire Ext 4KG MS SP	Launcher Automatic Fire Ext 6KG MS SP	Launcher Automatic Fire Ext 9KG MS SP
Agent	ABC Powder MAP 90	ABC Powder MAP 90	ABC Powder MAP 90
Throw (min.)	4 meters	6 meters	7 meters
Product Code	CF-000727	CF-000728	CF-000729
Certification type	PED, UKCA-PED, BSI Tested	PED, UKCA-PED, BSI Tested	PED, UKCA-PED, BSI Tested
PED	Yes	Yes	Yes
UKCA-PED	Yes	Yes	Yes
Gross Weight (approx.)	8.7 kg	11.5 kg	16.8 kg
Net Mass (approx.)	4 kg	6 kg	9 kg
Height of Fire Ext.(approx)	505 mm	545 mm	675 mm
Maximum Area Covered*	3.30 m <sup>2</sup>	5.88 m <sup>2</sup>	9.29 m <sup>2</sup>
Discharge Mechanism	Squeeze Grip / Automatic QBD***	Squeeze Grip / Automatic QBD***	Squeeze Grip / Automatic QBD***
Fire Ratings**	21A   144B	27A   183B	43A   233B
Can Construction	Deep Drawn & MIG Welded	Deep Drawn & MIG Welded	Deep Drawn & MIG Welded
Valve/Cap Construction	Forging and Machining	Forging and Machining	Forging and Machining
External Coating	Epoxy Polyester Powder	Epoxy Polyester Powder	Epoxy Polyester Powder
Warranty in Years	5	5	5
Min. Discharge Time	13 sec	15	23
Working Pressure	15 Bar	15 Bar	15 Bar
Dia. of Shell (OD)	140 mm	160 mm	175 mm
Operating Temp.	-30°C to +60°C	-30°C to +60°C	-30°C to +60°C
Hydrostatic Test Pressure	35 Bar	35 Bar	35 Bar
Body Thickness	1.6 mm	1.6 mm	2 mm
Schraeder Valve	Yes	Yes	Yes
Pressure relief valve	Yes	Yes	Yes

\*Maximum height of the extinguisher from the floor in enclosed area: 1.5 m.

\*\*Ratings are based on equivalent capacities of ABC Powder type Stored Pressure extinguishers.

### \*\*\*QUARTZOID BULB KEY (QBD)

● 57°C / 135°F   ● 68°C / 155°F   ● 79°C / 174°F   ● 93°C / 200°F   ● 141°C / 286°F   ● 182°C / 360°F   ● 227°C / 440°F



Scan the QR code to know more about the product



# Self Contained Watermist Based **Hydrant System**



## CF 3000 - HYDRANT SYSTEM

### OVERVIEW:

When a fire breaks out, external factors such as traffic and construction could prevent fire tenders from making it in time. To beat a fire, you need two important things on your side: quick response time and powerful firefighting equipment that's easily accessible and on the premises.

Ceasefire's CF 3000 is suitable for places with no ready supply of compressed air and water. It features an inbuilt pressure container, water storage and a foam supply unit. Pull out the long hose, activate the device and instantly be armed with CF 3000's immense fire fighting power.

### FEATURES:

- Fights all classes of fires.
- Standalone firefighting device.
- Thermal shock proof.
- Powered by Watermist and Foam.
- No power supply required.
- Effective use of water.



Scan the QR code to know more about the product



### TECHNICAL SPECIFICATIONS: HYDRANT SYSTEM

Nomenclature	Watermist Hydrant System
Product Code	CF-3000
Overall Dimensions	1200 x 370 x 1800 mm
Total Weight of Cabinet & Device (approx.)	300 kg
Length of Fire Hose	30 m
Nitrogen Gas Cylinder Capacity	70 L
Nitrogen Gas Pressure	300 Bar
Water Tank Capacity	60 L
Continuous Operating Time	4 min





# KITCHEN SUPPRESSION SYSTEMS

## IN THIS SECTION

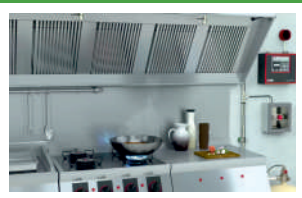

Commercial Kitchen  
Suppression Systems



Residential Kitchen  
Suppression Systems



# A FULL-SPECTRUM OF KITCHEN SYSTEMS

Ceasefire today offers an integrated range of kitchen fire suppression systems and fire extinguishers to suit the needs of every kind of a kitchen, be it a commercial

or residential. The range includes Watermist & Wet Chemical Engineered Systems & a host of hand-held extinguishers.



## Certified by the world's best agencies

Ceasefire's Commercial kitchen systems are fully certified by LPCB to LPS 1223 standard and the Residential systems are tested by BSI for performance & safety.



LPS 1223  
Cert/LPCB Ref. 1329a

Ceasefire's Kitchen Fire Suppression Range,  
Including Both Watermist & Wet Chemical Based Systems

**bsi.**

Tested by BSI

Ceasefire Domestic Kitchen  
Fire Suppression System

# WHAT MAKES CEASEFIRE KITCHEN SYSTEMS THE BEST IN THE WORLD?

## Customized Design For Every Kitchen

Ceasefire's Kitchen Fire Suppression Systems are designed following comprehensive structured design norms. The systems are configured specifically for a given kitchen site, and the installation details are laid out. These comply with the highest international standards.

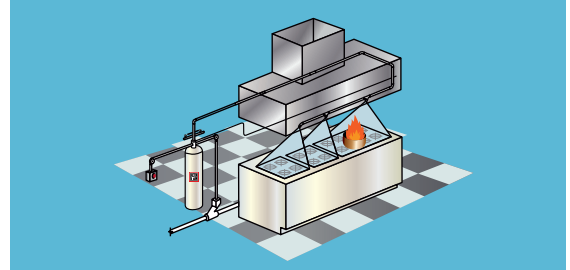
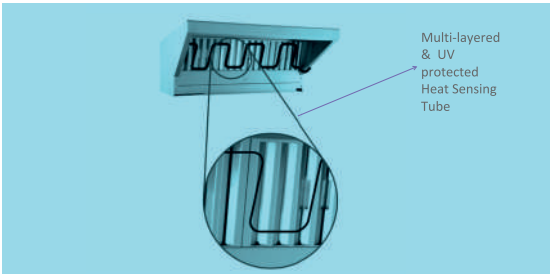

## Highly Advanced Heat Sensing Tube Based Fire Detection

The most prominent feature of the Ceasefire kitchen fire suppression systems is a specially designed, high grade, multilayered, pneumatic polymer tube that runs unobtrusively through out the area at risk. This tube offers robust detection with distinct puncture characteristics to form a perfect discharge port for the extinguishing agent.

## Next Generation Valve Technology

The System's valves are heavy duty, made of high-grade brass/stainless steel and with an integrated ball valve. This feature ensures against no leakages whatsoever.



## Nozzles That Leave No Blind Spots

At Ceasefire, our specially engineered nozzles ensure enhanced throw and their strategic positioning rules out any possibility of a blind spot in the kitchen.

## Intelligent Response Panel

The Ceasefire Kitchen Fire Suppression Systems come with an option of a state-of-the-art Response Panel that is capable of monitoring upto four cylinder systems. The Response Panel enables the users to monitor the health and functional readiness of the system with mere observation of indicators on the LCD screen. It also allows the users to integrate the system with other third party devices and systems present in the premises.



# EN 16282-7 COMPLIANT

EN 16282-7 is a European Standard that lays forth the technical safety, ergonomic, and hygienic standards for the design, manufacture, and use of kitchen ventilation hoods. The ventilation systems in commercial kitchens, related spaces, and other facilities processing meals meant for commercial use must comply with this European Standard. Kitchens and associated areas are special rooms in which meals are prepared, where tableware and equipment is washed, cleaned, food is stored and food waste areas. A process for verification

of each requirement is also well-defined.

By establishing uniform rules for performance testing, servicing & maintenance, and danger classifications such as fire, the new technical standard assists in bringing uniformity in regulations across the industry. The standard helps to better protect people, property, and businesses by bringing the restaurant industry closer to more effective commercial kitchen fire prevention.



## Performance tests by top-notch global quality agencies with world-class testing procedures

Ceasefire Commercial Kitchen Suppression Systems have been rigorously tested by world's best quality agencies on highest performance and safety standards. As a result of which, the systems have received LPCB certification with LPS1223 standard certification for both, Ceasefire's Watermist and Wet Chemical based commercial kitchen systems. These tests are conducted following the most stringent testing methods where these systems are tested on a wide variety of kitchen appliances, hoods and ducts. The tests take into consideration not just the fire extinguishing part of our systems but also the part of detection equally. What is more is that these tests are carried out after fixed interval post activation of detectors, mimicking real life situations.

01



02



## Installation by trained & certified service technicians

At Ceasefire, every Kitchen Suppression System is installed by a Ceasefire Trained Engineer / Technician. Each such engineer or technician is provided with a Ceasefire ID card with a unique id number, the records of which are hosted on a Ceasefire portal. This acts as a formal identity tool that helps in authentication of the identity of these personnel, whenever needed.

**Takes into account all fire scenarios that all kitchen appliances pose**

Most grease-producing appliance types and extraction duct work are tested by Ceasefire kitchen fire suppression systems. These systems are also tested for fryers with defined fire load (oil capacity) and surface area. Ceasefire kitchen fire suppression systems can protect any type of kitchen appliance, that may be utilizing any fuel type, within the defined limitations. To accommodate all sorts of kitchen appliances, hoods, and ducts, Ceasefire conducts rigorous tests as defined by LPS 1223, which also include testing the detection system in addition to the extinguishment [dousing]. Following the activation of detectors that simulate real-world conditions, a test is conducted after a predetermined interval.

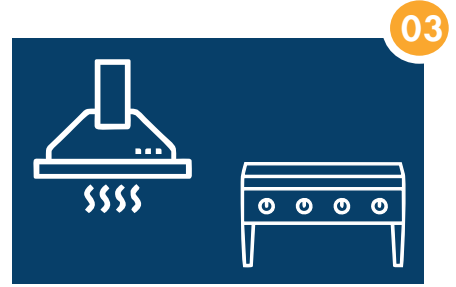

**All appliances present under the kitchen hood are protected uniformly**

Ceasefire Kitchen Fire Suppression systems are tested to ensure that all appliances that are listed as hazard and are present under the kitchen hood are protected from fire equally.

**Clear labels displaying compliance with the standard**

The Ceasefire Kitchen Fire Suppression systems wear standard certification labels and DOs and DON'Ts stickers, making it simple for anyone to use the system and visually identify compliance to EN 16282-7 standard.

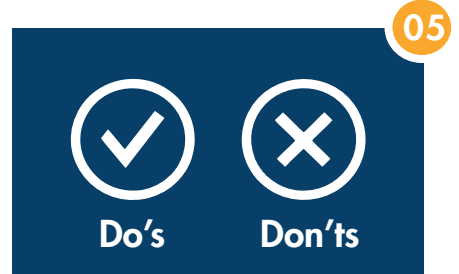

**Adherence to all applicable national rules and regulations**

Every Ceasefire metallic component complies with EN 10088-1 and is made of SS 304 or 316. The extinguishing agent itself functions as a cleaner and degreaser. The extinguishing agent for Ceasefire is environmentally benign and biodegradable.

**Additional crucial factors**

Ceasefire Kitchen Suppression Systems come with a highly reliable detection module that is ideally suited for the food services sector. Every system site is provided with a Log book and product manual enabling ease of use and maintenance of the systems. Ceasefire systems can accommodate more than one manual release at different escape routes. A highly advanced response panel takes the intelligence quotient of our systems to the next level including integration with third party devices.





# COMMERCIAL KITCHEN SUPPRESSION SYSTEMS - ENVIRO (WATERMIST BASED)

## OVERVIEW:

Ceasefire Watermist Kitchen Suppression System comes with an advanced heat detection mechanism. Its Pneumatic Heat Sensing Tube runs through the length of the hood, covering all vulnerable areas. In the event of a fire, this tube bursts at a set temperature point. This bursting of the tube allows the pressurised nitrogen to escape and the pressure to drop in the tube.

This fall of pressure activates the agent container valves, allowing the rotors placed inside the containers to mix air and water in pre-set proportions. The agent is then pushed through the discharge line and expelled from the strategically placed nozzles in the form of watermist, leaving no blind spots.

## FEATURES:

- > Works on Class A, B and F (cooking oil) fires.
- > Automatic detection and actuation.
- > Easy and convenient installation.
- > An eco-friendly alternative to conventional extinguishing systems.
- > Protects kitchen hood lengths upto 10 meters in single type nozzle.
- > Supported by trained Design & Support cell.

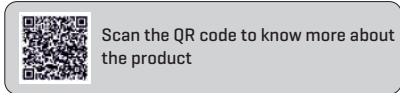

### Components of the System:

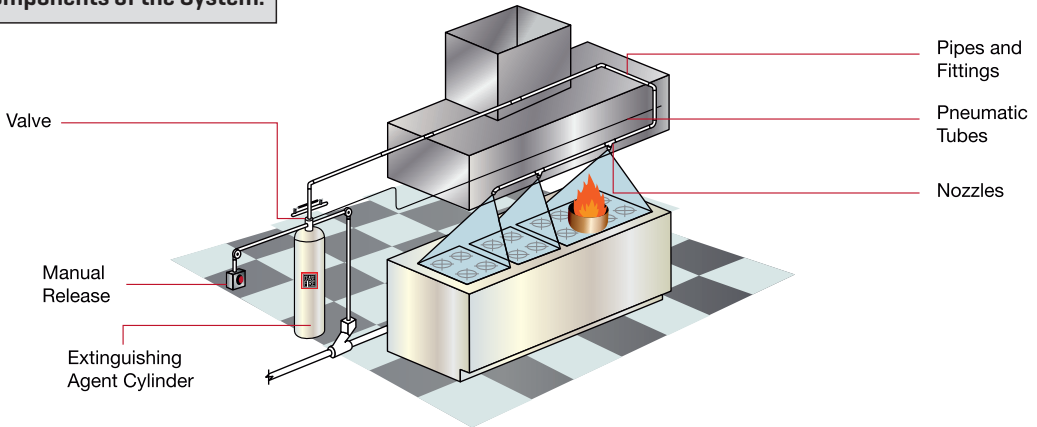

**Nozzles:** Specially designed nozzles that use minimum water and give maximum extinguishing power.

**Sizes available:** 11.5 ltr, 27 ltr & 56 ltr



## COMMERCIAL KITCHEN SUPPRESSION SYSTEMS - ULTRA (WET CHEMICAL BASED)

### OVERVIEW:

Hazardous oil and grease fires in kitchens take place when oil overheats from 350°C - 380°C. They are further enhanced by the accumulation of oil in the filter and the exhaust ducts of the kitchen hood. Kitchen fires are also caused by user error or malfunctioning equipment in electrical deep fat fryers.

The Ceasefire Wet Chemical Kitchen Suppression Systems are a perfect answer to such kitchen fires. The system, equipped with the advanced detection mechanism in the form of the heat sensing tube, is automatic and is capable of detecting fire and suppressing it even when there is no one around. The uniform detection by the heat sensing tube allows the users to freely move the hot and cold area under the kitchen hood at will.



### FEATURES:

- Works on Class A, B and F (cooking oil) fires.
- Automatic detection and actuation.
- Protects kitchen hood lengths upto 15 meters in single type nozzle.
- Easy and convenient installation.
- Supported by trained Design & Support cell.



LPS 1223  
Cert/LPCB Ref. 1329a



Scan the QR code to know more about the product

### Components of the System:

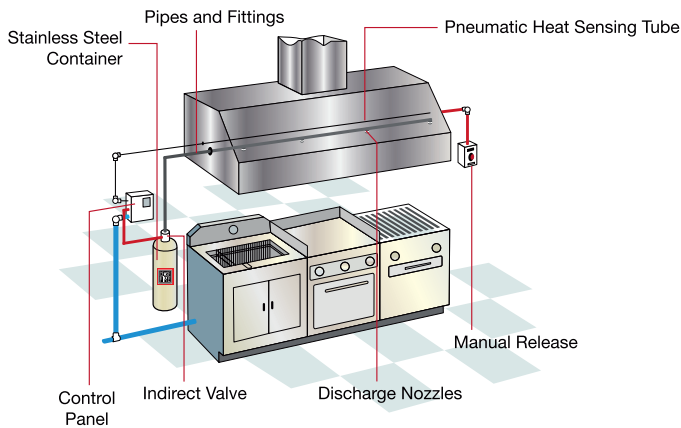

**Nozzles:** Specially designed nozzles that use minimum water and give maximum extinguishing power.

**Sizes available:** 11.5 ltr, 18 ltr & 27 ltr.



## RESIDENTIAL KITCHEN SUPPRESSION SYSTEMS - ENVIRO (WATERMIST BASED)

### OVERVIEW:

Ceasefire residential kitchen firefighting range is a modern system that operates automatically in the event of fire, making kitchen as safe as they can be.

Based on the clean watermist technology, the system does not cause any collateral damage and is safe for the kitchen equipment.

### FEATURES:

- Works on Class A, B and F [cooking oil] fires.
- Automatic detection and actuation.
- Camouflages with interiors of the kitchen.
- No collateral damage and minimal downtime.
- An eco-friendly alternative to conventional extinguishing systems.
- Easy and convenient installation that does not interfere with the kitchen hood or the decor.



Tested by **bsi.**



Scan the QR code to know more about the product

### Variants Available:

#### [1] 3 Litre, 2 Nozzles Variant [ideally suited for 600 mm kitchen hoods]

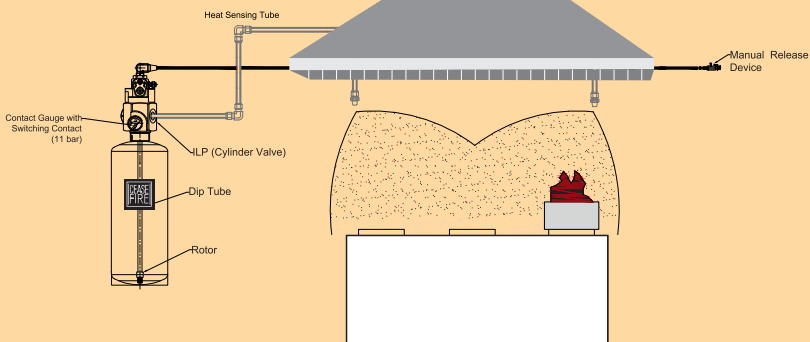

#### [2] 4.5 Litre, 3 Nozzles Variant [ideally suited for 900 mm kitchen hoods]

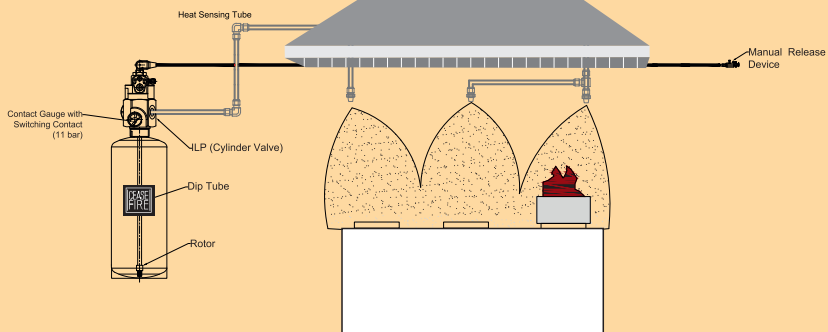

## RESIDENTIAL KITCHEN SUPPRESSION SYSTEMS - ULTRA (WET CHEMICAL BASED)

### OVERVIEW:

Ceasefire Wet chemical based residential kitchen suppression systems are fully automatic systems that detect fire with the advanced heat sensing tube. Wet chemical being a powerful extinguishing agent against cooking oil fires has a blanketing effect on the flames which cools the super heated oil to below its self-ignition point bringing the fire in control.

The system's unobtrusive design ensures that installing the system does not interfere with the kitchen hood or the decor.

### FEATURES:

- Works on Class A, B and F (cooking oil) fires
- Automatic detection and actuation.
- No collateral damage and zero downtime
- An eco-friendly alternative to conventional extinguishing systems.
- Easy and convenient installation that does not interfere with the kitchen hood or the decor.



Tested by **bsi.**



Scan the QR code to know more about the product

### Variants Available:

#### [1] 1 Litre, 1 Nozzle Variant

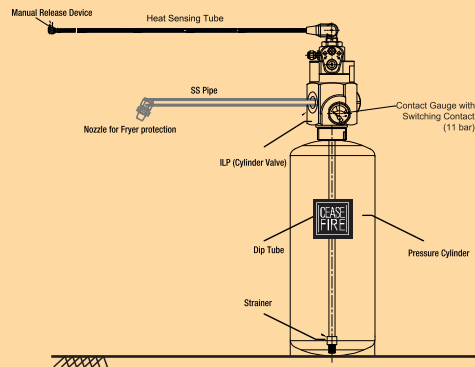

#### [2] 1 Litre, 2 Nozzles Variant

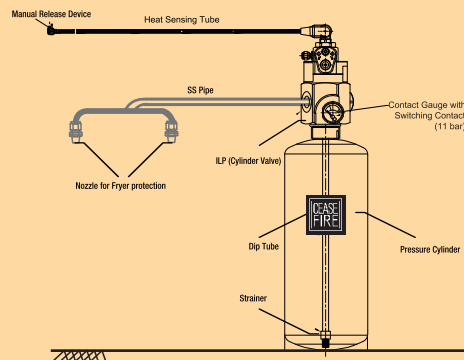

# WATERMIST SUPPRESSION SYSTEMS

## IN THIS SECTION



Generator Auto-Quell  
System

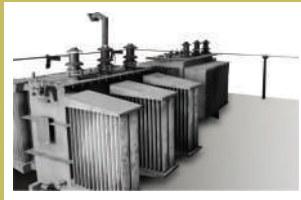

Transformer Auto-Quell  
System



Swift

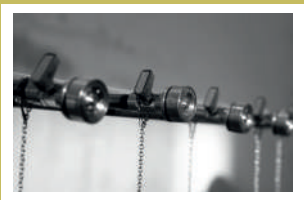

Indoor Auto-quell  
System





# WIDEST RANGE OF WATERMIST BASED SUPPRESSION SYSTEMS

Ceasefire offers a full-spectrum range of Watermist based suppression systems to suit the needs of every kind of premises and applications. These include highly

advanced Indoor Auto-Quell Systems, Specialized Systems for Generators, Transformers and Kitchen protection.

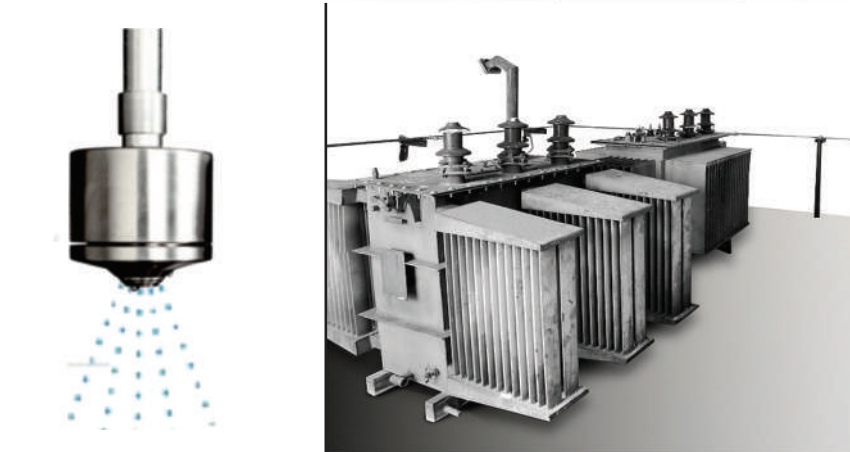

# WATERMIST – THE PARADIGM TECHNOLOGY

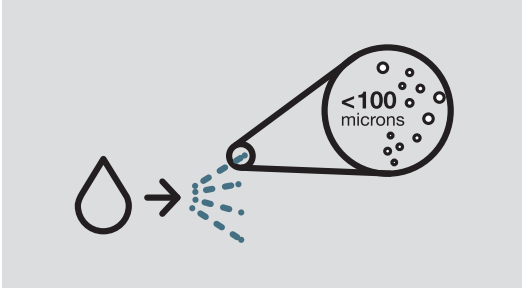

This pioneering technology breaks water down into a fine mist of less than 100 microns.



This mist is then thrown at the fire with an optimal kinetic force, covering a large surface area.

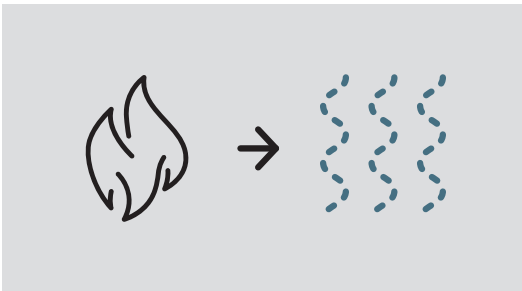

As soon as the mist comes in contact with the fire, it instantly turns into steam, increasing its volume 1600 times over.

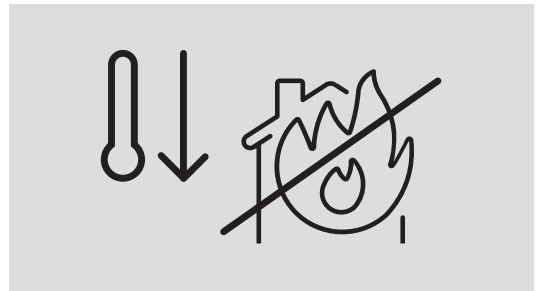

The steam envelops the flames, cutting off the oxygen supply and reducing the temperature to below combustion level. This ensures that even the largest fire succumbs to Watermist technology in seconds.

## Evaporation Surface Area & Shielding Surface Area

Various parameters like the force with which water is discharged, the size of water droplet and the nozzle coverage area, make the Watermist system ultra effective on fires. Conventional water-based suppression systems work on the principle of cooling the combustible surface with large droplets of water and hence totally drenching assets.

However, research has shown that the droplet size plays a vital role in killing the fire while protecting assets from collateral damage. When these fine droplets of water enter the fire zone, there is a rapid exchange of heat which cools the fire and converts the droplets into steam.

The smaller the size of the droplet, the larger is the surface area that it can cover for heat absorption and evaporation, thus resulting in lesser consumption of water to suppress the fire.



# WATERMIST GENERATION TECHNOLOGY

Watermist can only be generated when water is passed through the nozzles at a very high pressure. Ceasefire-

uses three technologies by which water can be converted to be a more potent fire extinguishing agent:



## 1. Pump-Based System

A large area where higher quantities of Watermist may be required to curb a fire needs a bigger source of water. In such cases, the water is stored in a local tank/reservoir which is connected to a pump and in the event of a fire, the high-powered pump propels water from the reservoir/tank efficiently to the pipes and specially designed nozzles.

## 2. Rotor-Based System

In cases where suppression systems protect smaller areas, a self-contained pulse mist-based system is used. Water is stored in nitrogen pressurised cylinders connected with detectors, pipes and nozzles. In an event of fire, the pressurised water is pushed through the specialised rotor and a little propellant (Nitrogen) is also released into the water pipe via an air tube to create a bubbled mixture of water and nitrogen which arrives at the nozzle.

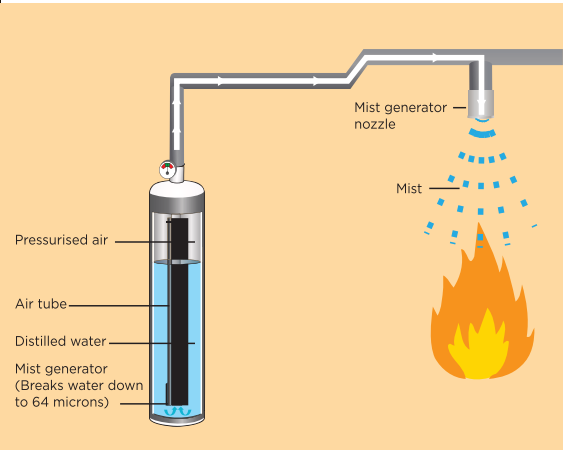

## 3. Large Quantity of Stored Compressed Air

In this system, compressed air is stored separately to be mixed with water only at the time of activation. When the system gets activated, water and compressed air mix together from two different sources to spray Watermist through the specialized nozzle.

# DETECTION SENSORS

The detection module of Ceasefire's watermist-based adjustable alarm system can be utilised with a wide range of alarm systems and can be tailored according to specific needs and requirements. It monitors and detects

the fire condition of the protected area, making the system more intelligent (not included in the standard package and to be sourced locally).

■ **Conventional Heat Detector**

■ **Rate of Rise Detector**

■ **Aspiration Detection System**

■ **Linear Heat Sensing Cable**

■ **Fixed Temperature Detector**

■ **Conventional Smoke Detector**

■ **Flame Detector**

■ **Conventional Heat Detector**



## NOZZLES

### OVERVIEW:

The minimal water usage, combined with Ceasefire nozzles generate super fine Watermist droplets, means the mist quickly vaporizes in the fire zone, surrounds the atmosphere and causes no harm to delicate equipments. By adjusting the nozzle variant, water volume and air pressure parameters, we can control the qualities of the mists it generates. Droplets can range in size from 10 microns to 150 microns while mist streams may be limited to several centimetres or extended up to 12 metres. This unique flexibility allows Ceasefire to create optimal mist solutions for a broad range of applications.

All the products at Ceasefire are extensively tested in the world's largest, purpose-built, state-of-art fire test laboratories to guarantee that even the largest scale designs are fully proven in real fire conditions.

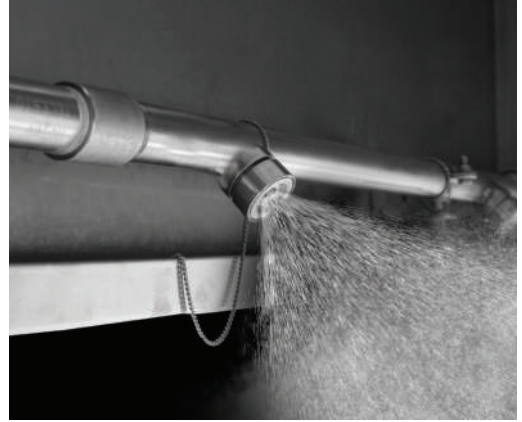

Our all-new range of Watermist Nozzles is broadly classified into:

#### Single Fluid-Based System

Here water and air have a single inlet and outlet. Under this application we have two types of nozzles –

**Open Nozzles** are those that are pressurised with water till the deluge or solenoid valve.

**Closed Nozzles** are those that are pressurised with the water up till the nozzle.



#### Twin Fluid Technology

Here there are two separate inlets and outlets for water and air to form Watermist. Only open nozzles can be utilised in this application.





## GENERATOR AUTO-QUELL SYSTEM

### OVERVIEW:

Generators produce a lot of heat. They're also powered by fuel, and placed in areas that are difficult to access quickly. By the time a fire is detected and put out, it could be too late.

The Ceasefire Watermist Suppression System is fully equipped to detect and suppress such fires automatically, without any collateral damage. Being Watermist-based, it tackles fires efficiently, and helps reduce the time and money taken to clean up and re-establish damaged property. With non-damaging, non-corrosive technology, it also ensures zero downtime.

### FEATURES:

- Works on Class A, B, C and Electrically charged devices.
- Does not require any power supply.
- Smart detection mechanism eliminates the need for human intervention.
- Offers 24x7 protection.
- Flexible tubing allows access to difficult areas easily.
- Environment-friendly.
- No collateral damage.
- Economical replacement for traditional sprinkler systems.
- Specially designed nozzles dispense microscopic droplets of water below 70 microns.



Scan the QR code to know more about the product

### The Complete System:

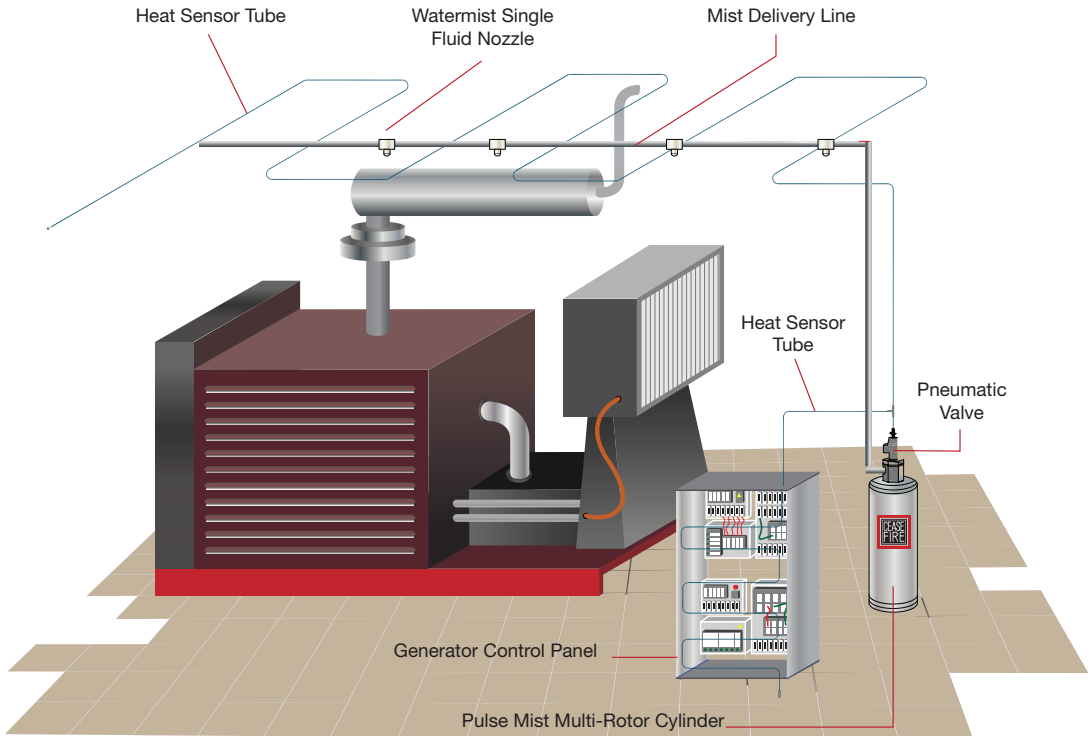

# TRANSFORMER AUTO-QUELL SYSTEM

## OVERVIEW:

Transformers are vital for any operation to run smoothly. But the oil that fuels them, coupled with high temperatures generated and the presence of electricity, makes the area vulnerable to fires. With transformers often being placed in remote areas or areas that aren't easily accessible, there's always the chance that a fire will not be extinguished in time.

The Ceasfire Watermist-based Suppression System is perfect for such environments as it self-activates, detects and suppresses the fire right when it ignites. Watermist confines the fire in or around the transformer area and extinguishes it before it spreads, thus ensuring zero collateral damage.

## FEATURES:

- > Works on Class A, B, C and electrically charged devices.
- > Does not require any power supply.
- > Smart detection mechanism eliminates the need for human intervention.
- > Offers 24x7 protection.
- > Flexible tubing allows access to difficult areas easily.
- > Environment-friendly.
- > No collateral damage.
- > Economical replacement for traditional sprinkler systems.

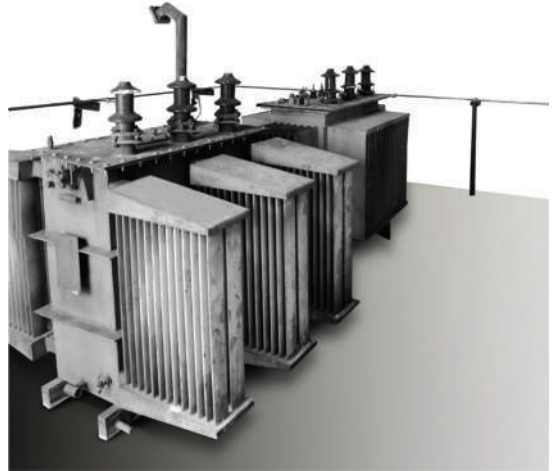

Tested by IBS



Scan the QR code to know more about the product

### The Complete System:

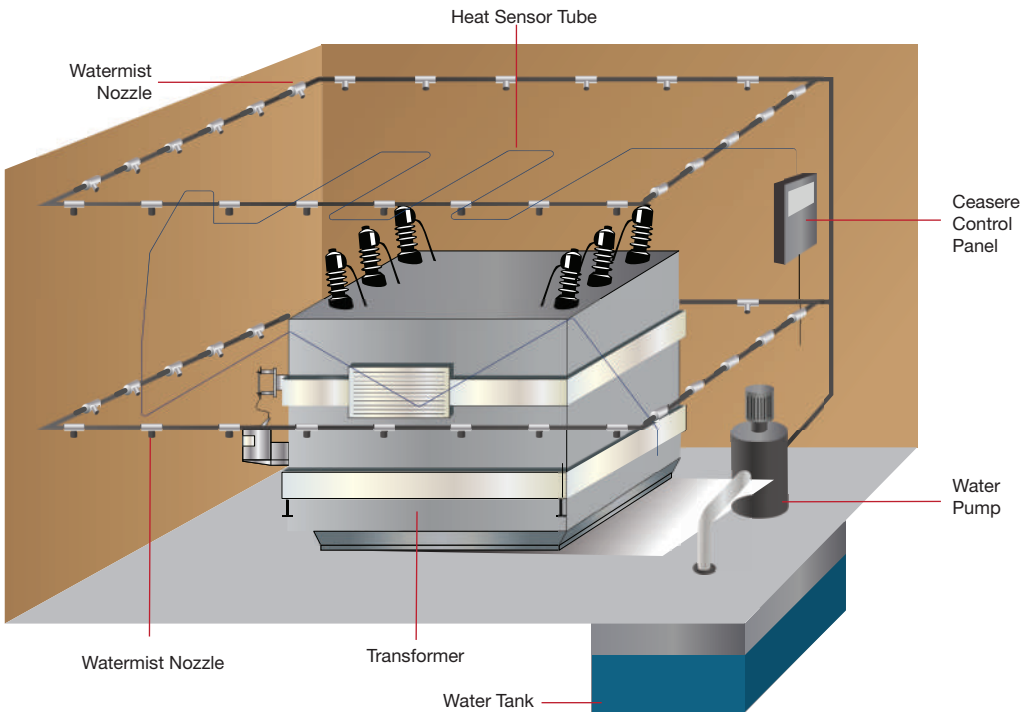

# SWIFT

## OVERVIEW:

Ceasefire's SWIFT [Self Activated Watermist Instant Flooding Technology] is an automatic watermist based total flooding system that is designed to not only extinguish flames effectively but also reduce the risk of collateral damage to a very large extent. The agent being fine mist evaporates rapidly when dispersed on fire, bringing down temperature to below combustion levels and extinguish flames quickly.

The system is designed to protect large spaces and are ideally suited for spaces with sensitive equipment and expensive machinery.

## FEATURES:

- Works on Class A, B, C, and fires involving electrically charged devices.
- No damage to human life or property.
- Covers a larger surface.
- Cost effective, eco-friendly alternative to chemical systems.

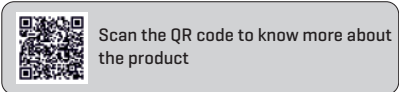

## The Complete System:

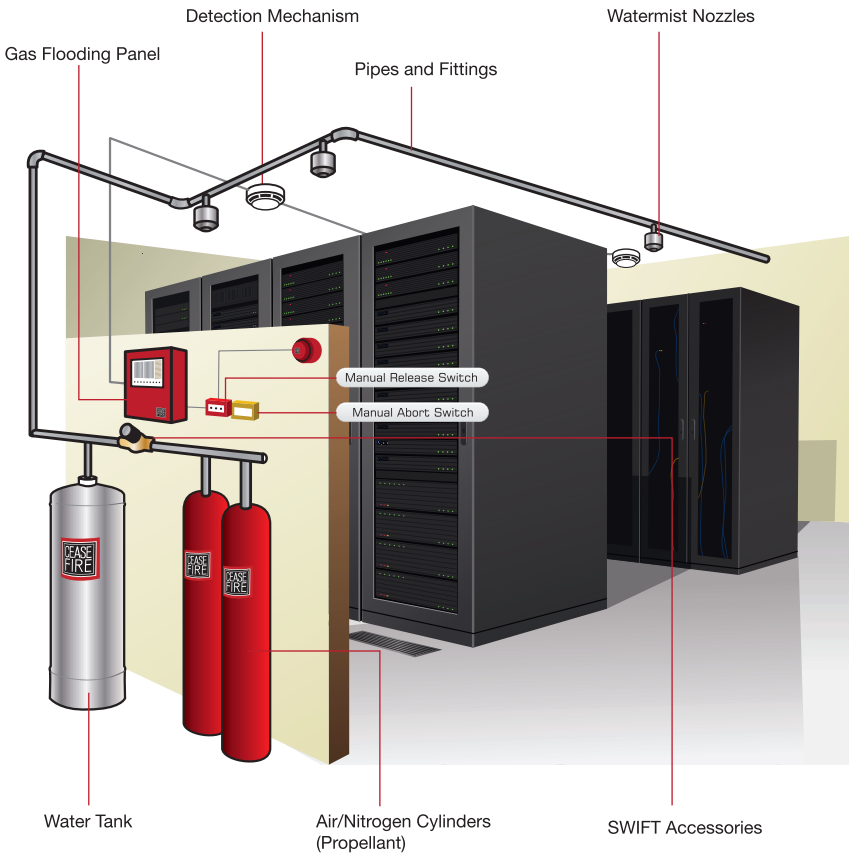

## INDOOR AUTO-QUELL SYSTEM

### OVERVIEW:

The Ceasefire Watermist Auto-Quell System is a revolutionary, all-purpose detection and fire suppressant system solution. A network of detection devices, special watermist nozzles and a connection to a water tank is installed indoors. In the event of a fire, the system kicks into action in seconds.

The specially designed nozzles dispense watermist, onto the fire affected area, quickly putting out the flames as well as bringing the temperature down to non-combustion levels.

### FEATURES:

- Works on Class A, B, C and Electrically started fires, and is suitable for a variety of applications.
- Smart detection mechanism eliminates the need for human intervention.
- Offers 24x7 protection.
- Flexible tubing allows access to difficult areas easily.
- Environment-friendly.
- No collateral damage.
- Reduced water consumption.
- Economical replacement for traditional sprinkler systems.



Scan the QR code to know more about the product

### The Complete System:

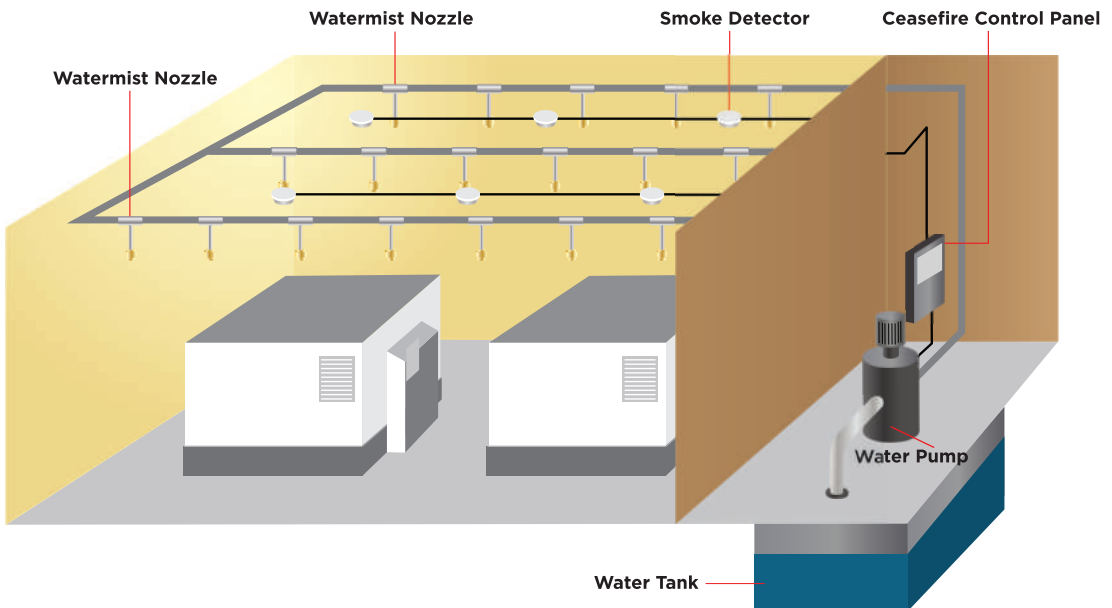

# WINNING TRUST WORLDWIDE

Decades of safeguarding lives and protecting assets worldwide with over **3 million Fire Extinguishers** and over **25000 Specialised Fire Suppression Systems** protecting wide range of spaces like Rooms, Kitchens,

Electrical Panels, Server Racks, Mobile Towers, Machinery and more for our clients ranging from Start Ups to Unicorns and some of the biggest **global corporate giants**.



HONDA



HSBC



HYUNDAI



MARUTI SUZUKI



mitsubishi



Nestlé



ORIFLAME SWEDEN



PUMA



RBS



Reckitt Benckiser



SAMSUNG



SIEMENS  
Ingenuity for life



Unilever



unicef



vodafone

and Many More...



## Ceasefire Industries UK Limited

Office Number 301.3 One Victoria Square, Birmingham West  
Midlands B1 1BD, United Kingdom

Tel: 0-113-868-6666 / 0-126-891-9999

Website : [www.ceasefire.co.uk](http://www.ceasefire.co.uk)



Scan the QR code  
to visit our website

Follow us on:



Regular R&D and product improvisations may lead to change in product specifications in this catalogue, without any prior notice.