

ABC POWDER PORTABLE EXTINGUISHERS (MAP 50) STORED PRESSURE

PRODUCT OVERVIEW

Fire is a very potent enemy and when it strikes, it doesn't give much time to gather a reaction. Fires can prove dangerous if it goes undetected. Therefore, it is imperative to keep a portable fire extinguisher handy. ABC dry powder-based extinguishers are built for speed, power, and reliability. Ceasefire's MAP 50 extinguishers contain a 50% concentration of Mono Ammonium Phosphate, which in turn maximizes the fire fighting power. When sprayed, the dry powder absorbs the heat, melts, and fuses to form a thin transparent layer. This, in turn, does not allow oxygen to come into contact with the hot surface thereby, preventing re-ignition. It fights against classes A, B, C, and Electrically started fires.



ENGINEERING DRAWINGS

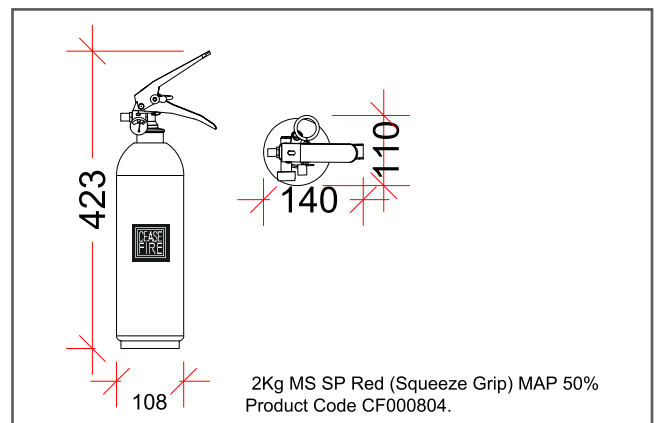
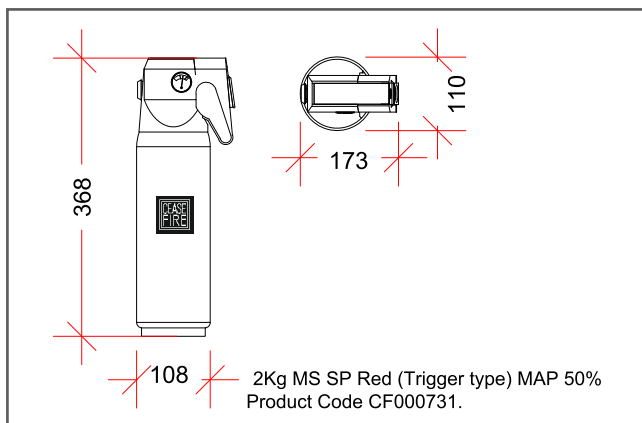
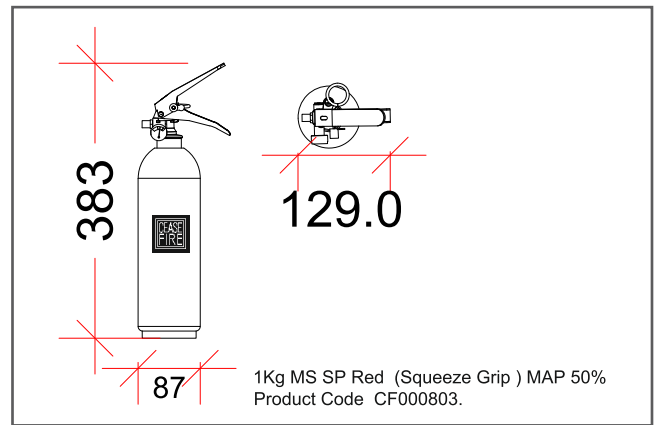
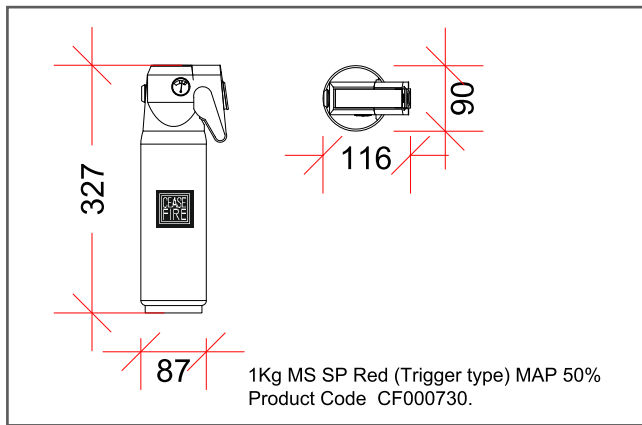

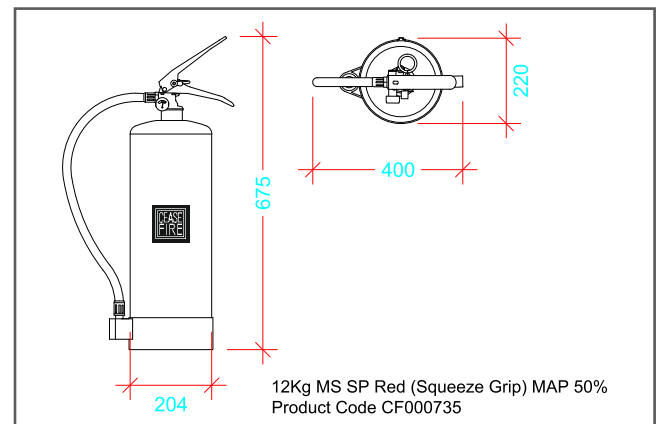
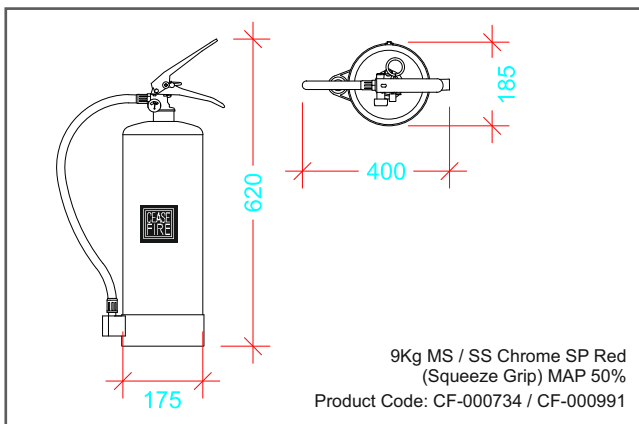
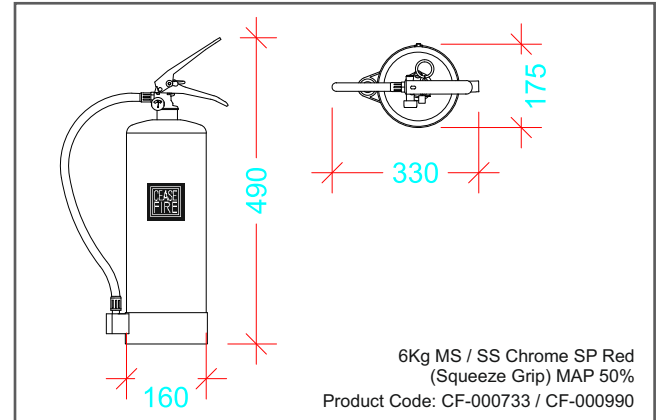
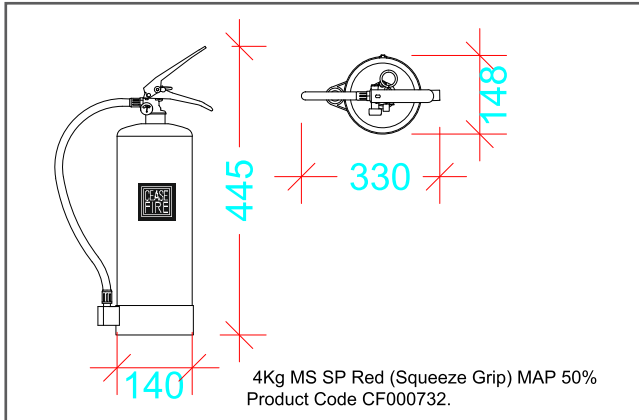

TECHNICAL SPECIFICATIONS

Product Code	UOM	CF-000803	CF-000804	CF-000730	CF-000731	CF-000732
Description	—	Cease Fire MAP 50% 1Kg MS SP Red (Squeeze Grip)	Ceasefire MAP 50% 2 KG MS SP Red (Squeeze Grip)	Cease Fire MAP 50% 1Kg MS SP Red (Trigger type)	Ceasefire MAP 50% 2 KG MS SP Red (Trigger type)	Ceasefire MAP 50% 4 KG MS SP Red (Squeeze Grip)
Capacity of Agent	L	1±5%	2±3%	1±5%	2±3%	4±2%
Certification	—	PED EN3	PED EN3	PED EN3	PED EN3	PED EN3
Diameter of Shell	MM	86.5	108	86.5	108	140
Total Height (approx.)		350	370	325	345	440
MOC of Shell	—	Steel Cr2 (DC01)	Steel Cr2 (DC01)	Steel Cr2 (DC01)	Steel Cr2 (DC01)	Steel Cr2 (DC01)



Product Code	UOM	CF-000803	CF-000804	CF-000730	CF-000731	CF-000732
Mini. Wall Thickness	MM	1.0	1.4	1.0	1.4	1.2
Test Pressure	BAR	35	35	35	35	35
Anti-Corrosive Treatment	—	Outer surfaces are EP powder coated having a thickness of 50-micron min. RAL Shade 3000	Outer surfaces are EP powder coated having a thickness of 50-micron min. RAL Shade 3000	Outer surfaces are EP powder coated having a thickness of 50-micron min. RAL Shade 3000	Outer surfaces are EP powder coated having a thickness of 50-micron min. RAL Shade 3000	Outer surfaces are EP powder coated having a thickness of 50-micron min. RAL Shade 3000
Service Pressure	BAR	15	15	15	15	15
Type of Operating Mechanism	—	Squeeze Grip with NRV and Burst Disc.	Squeeze Grip with NRV and Burst Disc.	Trigger type	Trigger Type	Squeeze Grip with NRV and Burst Disc.
Type of Pressure Gauge	—	Magnetic Bourdon Tube Type	Magnetic Bourdon Tube Type	Magnetic Bourdon Tube Type	Magnetic Bourdon Tube Type	Magnetic Bourdon Tube Type
Type of Dis. Fitting & Length	MM	Direct Nozzle	Direct Nozzle	Direct Nozzle	Direct Nozzle	EPDM Rubber Braided Hose Pipe with nozzle Length of Hose 500 mm
Throw	METER	3	3.5	3	3.5	4
Min. Discharge Time	SEC.	7	11	8	11	16
Fire Rating	—	5A 34B	8A 70B	5A 34B	8A 70B	21A 144B
Operating Temperature Range	°C	From -30°C to + 60°C	From -30°C to + 60°C	From -30°C to + 60°C	From -30°C to + 60°C	From -30°C to + 60°C
Applicable to Type of Fire	—	A, B, C, & Electrical Started Fire	A, B, C, & Electrical Started Fire	A, B, C, & Electrical Started Fire	A, B, C, & Electrical Started Fire	A, B, C, & Electrical Started Fire
Filled Weight Range*	KG	Approx. 1.98	Approx. 3.40	Approx. 1.98	Approx. 3.40	Approx. 6.50
Packed Weight Range (approx)**	KG	2.6	4	2.68	4.1	7.45

Product Code	UOM	CF-000803	CF-000804	CF-000730	CF-000731	CF-000732
Packed Size Length x Width x Height	MM	125 x 115 x 400	130 x 140 x 415	125 x 115 x 400	130 x 140 x 415	160 x 160 x 470
Product Warranty	YEAR	5	5	5	5	5

*It includes Empty Extinguisher, Contents, Plastic Base, Hose / Horn and bracket.

*It includes Empty Extinguisher, Packaging, Contents, Plastic Base, Hose / Horn and bracket.

CERTIFICATIONS

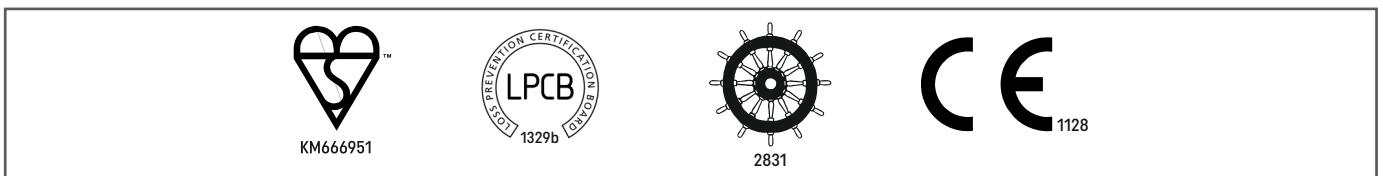

PRODUCT PICTURES



1 KG

1 KG

2 KG

2 KG

4 KG



TECHNICAL SPECIFICATIONS

Product Code	UOM	CF-000733	CF-000990	CF-000734	CF-000991	CF-000735
Description	—	Ceasefire MAP 50% 6 KG MS SP Red (Squeeze Grip)	Ceasefire MAP 50% 6 KG MS SP Chrome (Squeeze Grip)	Ceasefire MAP 50% 9 KG MS SP Red (Squeeze Grip)	Ceasefire MAP 50% 9 KG MS SP Chrome (Squeeze Grip)	Ceasefire MAP 50% 12 MS SP Red (Squeeze Grip)
Capacity of Agent	L	6±2%	6±2%	9±2%	9±2%	12±2%
Certification	—	PED EN3	PED	PED EN3	PED	EN3 PED MED
Diameter of Shell	MM	160	160	175	175	204
Total Height (approx.)		485	485	615	615	665
MOC of Shell	—	Steel Cr2 (DC01)	SS 304 (1.4301)	Steel Cr2 (DC01)	SS 304 (1.4301)	Steel Cr2 (DC01)
Mini. Wall Thickness	MM	1.4	1.5	1.4	1.5	1.6
Test Pressure	BAR	35	35	35	35	35
Anti-Corrosive Treatment	—	Outer surfaces are EP powder coated having a thickness of 50-micron min. RAL Shade 3000	NA	Outer surfaces are EP powder coated having a thickness of 50-micron min. RAL Shade 3000	NA	Outer surfaces are EP powder coated having a thickness of 50-micron min. RAL Shade 3000
Service Pressure	BAR	15	15	15	15	15
Type of Operating Mechanism	—	Squeeze Grip with NRV and Burst Disc.	Squeeze Grip with NRV and Burst Disc.	Squeeze Grip with NRV and Burst Disc.	Squeeze Grip with NRV and Burst Disc.	Squeeze Grip with NRV and Burst Disc.
Type of Pressure Gauge	—	Magnetic Bourdon Tube Type	Magnetic Bourdon Tube Type	Magnetic Bourdon Tube Type	Magnetic Bourdon Tube Type	Magnetic Bourdon Tube Type
Type of Dis. Fitting & Length	MM	EPDM Rubber Braided Hose Pipe with nozzle Length of Hose 500 mm	EPDM Rubber Braided Hose Pipe with nozzle Length of Hose 500 mm	EPDM Rubber Braided Hose Pipe with nozzle Length of Hose 750 mm	EPDM Rubber Braided Hose Pipe with nozzle Length of Hose 750 mm	EPDM Rubber Braided Hose Pipe with nozzle Length of Hose 800 mm
Throw	METER	6	6	7	7	7



Product Code	UOM	CF-000733	CF-000990	CF-000734	CF-000991	CF-000735
Min. Discharge Time	SEC.	21	21	18	18	25
Fire Rating	—	27A 183B	27A 183B	43A 233B	43A 233B	55A 233B
Operating Temperature Range	°C	From -30°C to + 60°C	From -30°C to + 60°C	From -30°C to + 60°C	From -30°C to + 60°C	From -30°C to + 60°C
Applicable to Type of Fire	—	A, B, C, & Electrical Started Fire	A, B, C, & Electrical Started Fire	A, B, C, & Electrical Started Fire	A, B, C, & Electrical Started Fire	A, B, C, & Electrical Started Fire
Filled Weight Range*	KG	Approx. 9.30	Approx. 9.50	Approx. 13.40	Approx. 13.30	Approx. 17.70
Packed Weight Range (approx)**	KG	10.1	10.1	15.5	15.5	19.85
Packed Size Length x Width x Height	MM	175 x 175 x 715	175 x 175 x 715	190 x 195 x 650	190 x 195 x 650	215 x 215 x 715
Product Warranty	YEAR	5	5	5	5	5

*It includes Empty Extinguisher, Contents, Plastic Base, Hose / Horn and bracket.

**It includes Empty Extinguisher, Packaging, Contents, Plastic Base, Hose / Horn and bracket.

CERTIFICATIONS

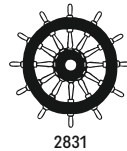

PRODUCT PICTURES



6 KG

6 KG

9 KG

9 KG

12 KG

*v1' Published Date is 31-07-2022.

**Regular R&D and product improvisations may lead to change in product specifications in this data sheet, without any prior notice.