

CO₂ BASED PORTABLE EXTINGUISHERS

PRODUCT OVERVIEW

A small fire can grow into a lethal blaze within seconds, and especially difficult to control are the volatile class B and C fires. These fires burn on flammable liquids and gases, that spread very fast and are extremely difficult to contain. Specially designed for such fires is the Ceasefire CO₂ based extinguishers. These extinguishers are packed with tremendous power, and are very effective in putting out these volatile class B and C fires. Ceasefire has a wide range of CO₂ based extinguishers that are available in a number of variants to choose from.



Extremely user-friendly, with a protective cover over the valve to avoid the risk of freeze burn, Ceasefire's CO₂ type extinguishers are the perfect weapon against large, hard-to-fight B and C class fires. This system makes use of Carbon Dioxide which is also known as dry ice. Due to its non-corrosive nature, it doesn't leave behind any residue after being sprayed to extinguish fires. At the same time, it causes no harm to the environment.

ENGINEERING DRAWINGS (with used & ready mechanism)

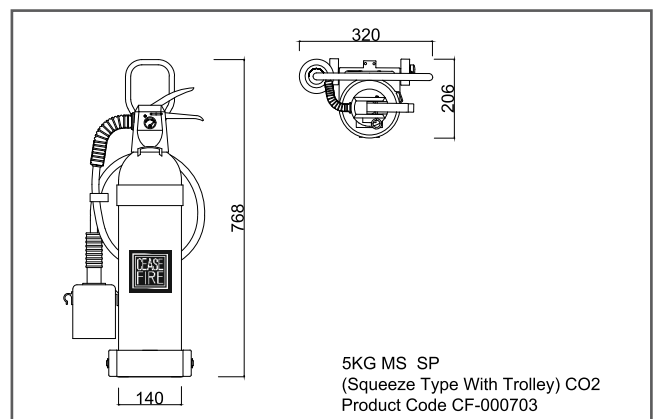
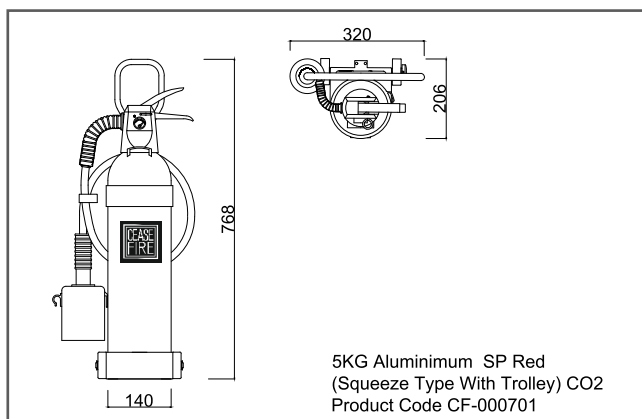
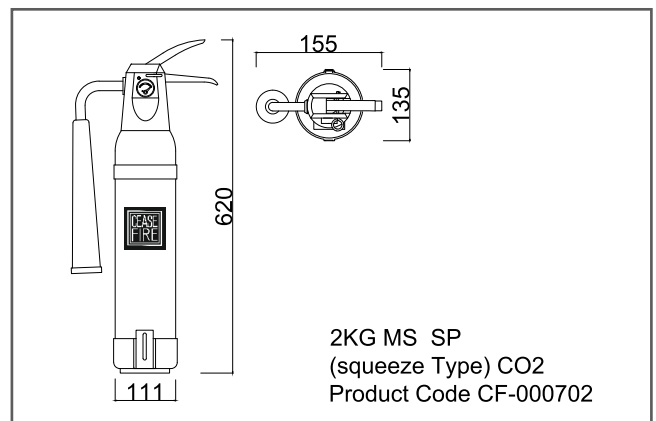
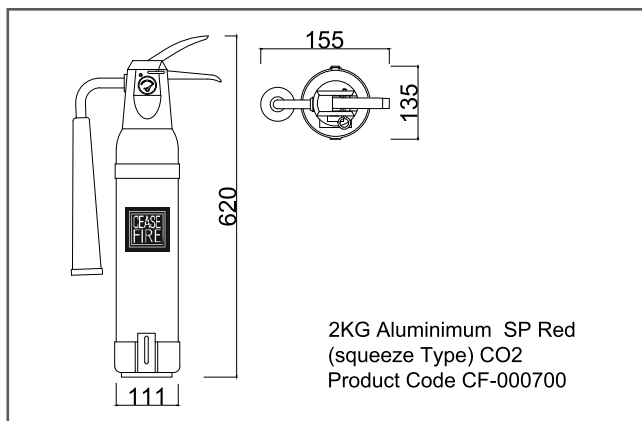

ENGINEERING DRAWINGS

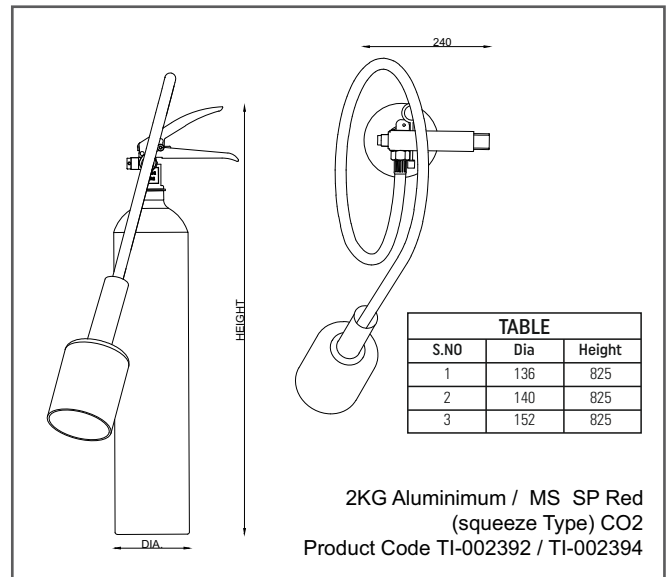
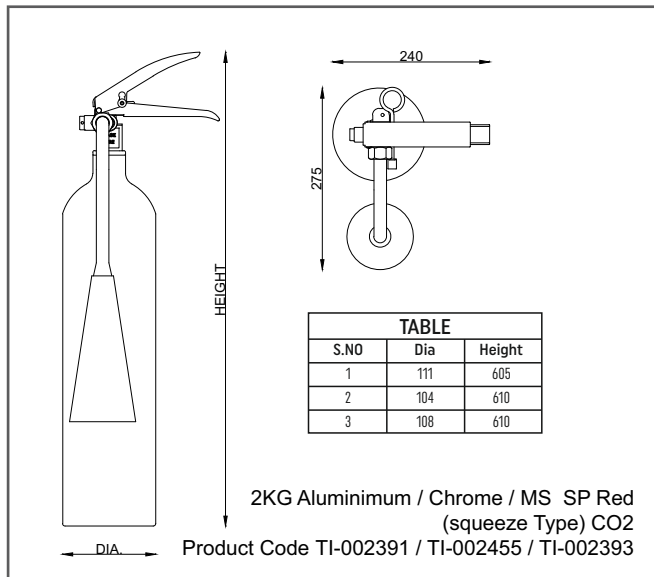

TECHNICAL SPECIFICATIONS (with used & ready mechanism)

Product Code	UOM	CF-000700	CF-000702	CF-000701	CF-000703
Description	—	Fire Ext CO2 2KG Aluminium squeeze Grip SP Red	Fire Ext CO2 2KG MS squeeze Grip SP	Fire Ext CO2 5KG Aluminium squeeze Grip with Trolley SP Red	Fire Ext CO2 5KG MS squeeze Grip with Trolley SP
Capacity of Agent	KG	2-5%	2-5%	5-5%	5-5%
Certification	—	PED EN3	PED EN3	PED EN3	PED EN3
Diameter of Shell	MM	108	108	152	140
Total Height (approx.)	MM	605	610	825	825
MOC of Shell	—	Al Alloy 6061	M.S.(37Mn)	Al Alloy 6061	M.S.(37Mn)
Min. Wall Thickness	MM	6	3.5	7.3	3



Product Code	UOM	CF-000700	CF-000702	CF-000701	CF-000703
Test Pressure	BAR	250	250	250	250
Anti-Corrosive Treatment	—	Outer surfaces were EP Powder coated having Thickness 50 Micron Min. RAL Shade 3000	Outer surfaces were EP Powder coated having Thickness 50 Micron Min. RAL Shade 3000	Outer surfaces were EP Powder coated having Thickness 50 Micron Min. RAL Shade 3000	Outer surfaces were EP Powder coated having Thickness 50 Micron Min. RAL Shade 3000
Service Pressure	BAR	70	70	70	70
Type of Operating Mechanism	—	Squeeze Grip with Burst Disc.	Squeeze Grip with Burst Disc.	Squeeze Grip with Burst Disc.	Squeeze Grip with Burst Disc.
Type of Pressure Gauge	—	NA	NA	NA	NA
Type of Dis. Fitting & Length	MM	Bend and Horn Assembly	Bend and Horn Assembly	EPDM Rubber Braided Hose Pipe with nozzle Length of Hose 1000 mm	EPDM Rubber Braided Hose Pipe with nozzle Length of Hose 1000 mm
Throw	METER	3	3	4	4
Min. Discharge Time	SEC.	6	6	9	9
Fire Rating	—	34B	34B	70B	70B
Operating Temperature Range	°C	From -30°C to + 60°C	From -30°C to + 60°C	From -30°C to + 60°C	From -30°C to + 60°C
Applicable to Type of Fire	—	B, C & Electrical Started Fire	B, C & Electrical Started Fire	B, C & Electrical Started Fire	B, C & Electrical Started Fire
Filled Weight Range*	KG	6.5	8.7	13	17.6

Product Code	UOM	CF-000700	CF-000702	CF-000701	CF-000703
Packed Weight Range (approx)**	KG	7.4	9.54	16.1	20.7
Packed Size Length x Width x Height	MM	160 x 175 x 650	160 x 175 x 650	230 x 250 x 820	230 x 250 x 820
Product Warranty	-	5	5		5

*It includes Empty Extinguisher, Contents, Plastic Base, Hose / Horn and bracket.

**It includes Empty Extinguisher, Contents, Packaging, Plastic Base, Hose / Horn and bracket.

CERTIFICATIONS

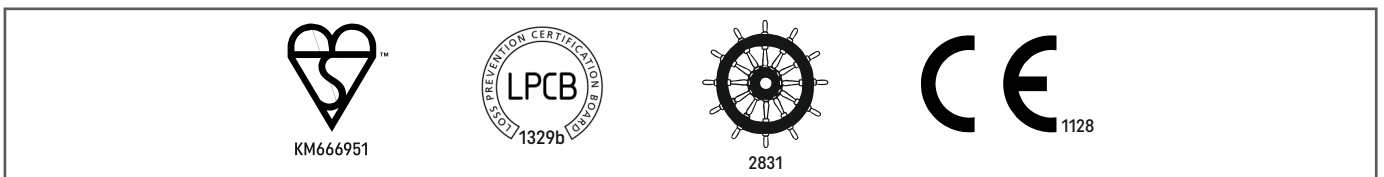

PRODUCT PICTURES



2 KG



5 KG



TECHNICAL SPECIFICATIONS

Product Code	UOM	TI-002391	TI-002455	TI-002393	TI-002392	TI-002394
Description	—	Fire Ext CO2 2KG Aluminium squeeze Grip SP Red	Fire Ext CO2 2KG Aluminium squeeze Grip SP Chrome	Fire Ext CO2 2KG MS squeeze Grip SP Red	Fire Ext CO2 5KG Aluminium squeeze Grip SP Red	Fire Ext CO2 5KG MS squeeze Grip SP Red
Capacity of Agent	KG	2 - 5%	2 - 5%	2 - 5%	5 - 5%	5 - 5%
Certification	—	PED EN3	PED	PED EN3	PED EN3	PED EN3
Diameter of Shell	MM	111	111	108 / 104	140 / 152 / 152	136 / 140
Total Height (approx.)		605	605	610	825	825
MOC of Shell	—	Al / Al / Alloy 6061	Al / Al / Alloy 6061	37Mn / 34CRMO4	Al / Alloy 6061 / Al	37Mn / 37CrMo4
Min. Wall Thickness	MM	5.6 / 5.7 / 6.0	5.6 / 5.7 / 6.0	2 / 3.5	5.6 / 7.06 / 8.7	2.6 / 3
Test Pressure	BAR	250	250	250	250	250
Anti-Corrosive Treatment	—	Outer surfaces were EP Powder coated having Thickness 50 Micron Min. RAL Shade 3000	Outer surfaces were EP Powder coated having Thickness 50 Micron Min. RAL Shade 3000	Outer surfaces were EP Powder coated having Thickness 50 Micron Min. RAL Shade 3000	Outer surfaces were EP Powder coated having Thickness 50 Micron Min. RAL Shade 3000	Outer surfaces were EP Powder coated having Thickness 50 Micron Min. RAL Shade 3000
Service Pressure	BAR	62	62	62	67	70
Type of Operating Mechanism	—	Squeeze Grip with Burst Disc.	Squeeze Grip with Burst Disc.	Squeeze Grip with Burst Disc.	Squeeze Grip with Burst Disc.	Squeeze Grip with Burst Disc.
Type of Pressure Gauge	—	NA	NA	NA	NA	NA
Type of Dis. Fitting & Length	MM	Bend and Horn Assembly	Bend and Horn Assembly	Bend and Horn Assembly	EPDM Rubber Braided Hose Pipe with nozzle Length of Hose 1000 mm	EPDM Rubber Braided Hose Pipe with nozzle Length of Hose 1000 mm
Throw	METER	3	3	3	4	4



Product Code	UOM	CF-001406	CF-001407	CF-001408	CF-001409	CF-001410
Min. Discharge Time	SEC.	6	6	6	9	9
Fire Rating	—	55B	55B	89B	89B	34B
Operating Temperature Range	°C	From -30°C to + 60°C	From -30°C to + 60°C	From -30°C to + 60°C	From -30°C to + 60°C	From -30°C to + 60°C
Applicable to Type of Fire	—	B, C & Electrical Started Fire	B & Electrical Started Fire	B, C & Electrical Started Fire	B, C & Electrical Started Fire	B, C & Electrical Started Fire
Filled Weight Range*	KG	6.40 to 6.60	Approx. 6.50	8.70 to 8.90	Approx. 12.122	Approx. 16.707
Packed Weight Range (approx)**	KG	2.68	4.2	7.45	10.1	15.5
Packed Size Length x Width x Height	MM	125 X 115 X 400	130 X 140 X 415	160 X 160 X 470	175 X 175 X 715	190 X 195 X 650
Product Warranty	YEAR	5	5	5	5	5

*It includes Empty Extinguisher, Contents, Plastic Base, Hose / Horn and bracket.

**It includes Empty Extinguisher, Contents, Packaging, Plastic Base, Hose / Horn and bracket.

CERTIFICATIONS

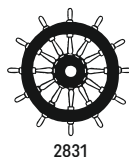

PRODUCT PICTURES



*v1' Published Date is 31-07-2022.

**Regular R&D and product improvisations may lead to change in product specifications in this data sheet, without any prior notice.